

harman/kardon

HK3480 STEREO RECEIVER

SERVICE MANUAL



CONTENTS

ESD WARNING.....	2	DISASSEMBLY PROCEDURES.....	17
LEAKAGE TESTING.....	3	EXPLODED VIEW	20
SPECIFICATIONS	4	BLOCK DIAGRAM.....	21
FRONT PANEL CONTROLS	5	FRONT PANEL DISPLAY.....	22
REAR PANEL CONNECTIONS	8	IC DESCRIPTIONS/PINOUTS.....	26
REMOTE CONTROL FUNCTIONS	10	ELECTRICAL PARTS LIST	40
TROUBLESHOOTING GUIDE.....	12	PCB DRAWINGS.....	46
PROCESSOR RESET.....	12	SCHEMATICS.....	48
AMPLIFIER BIAS ADJUSTMENT.....	13	WIRING DIAGRAM.....	54
BULLETIN HK2003-10.....	14	PACKAGE.....	55
BULLETIN HK2004-02.....	16		

harman/kardon, Inc.
250 Crossways Park Dr.
Woodbury, New York 11797

Rev2 2/2006

ELECTROSTATICALLY SENSITIVE (ES) DEVICES

Some semiconductor (solid state) devices can be damaged easily by static electricity. Such components commonly are called Electrostatically Sensitive (ES) Devices. Examples of typical ES devices are integrated circuits and some field effect transistors and semiconductor "chip" components.

The following techniques should be used to help reduce the incidence of component damage caused by static electricity.



1. Immediately before handling any semiconductor component or semiconductor-equipped assembly, drain off any electrostatic charge on your body by touching a known earth ground. Alternatively, obtain and wear a commercially available discharging wrist strap device, which should be removed for potential shock reasons prior to applying power to the unit under test.
2. After removing an electrical assembly equipped with ES devices, place the assembly on a conductive surface such as aluminum foil, to prevent electrostatic charge build-up or exposure of the assembly.
3. Use only a grounded-tip soldering iron to solder or unsolder ES devices.
4. Use only an anti-static solder removal device. Some solder removal devices not classified as "anti-static" can generate electrical charges sufficient to damage ES devices.
5. Do not use freon-propelled chemicals. These can generate electrical charge sufficient to damage ES devices.
6. Do not remove a replacement ES device from its protective package until immediately before you are ready to install it. (Most replacement ES devices are packaged with leads electrically shorted together by conductive foam, aluminum foil or comparable conductive material.)
7. Immediately before removing the protective material from the leads of a replacement ES device, touch the protective material to the chassis or circuit assembly into which the device will be installed.

CAUTION : Be sure no power is applied to the chassis or circuit, and observe all other safety precautions.

8. Minimize bodily motions when handling unpackaged replacement ES devices. (Otherwise harmless motion such as the brushing together of your clothes fabric or the lifting of your foot from a carpeted floor can generate static electricity sufficient to damage an ES devices.

PRODUCT SAFETY NOTICE

Each precaution in this manual should be followed during servicing.

Components identified with the IEC symbol  in the parts list are special significance to safety. When replacing a component identified with , use only the replacement parts designated, or parts with the same ratings or resistance, wattage, or voltage that are designated in the parts list in this manual. Leakage-current or resistance measurements must be made to determine that exposed parts are acceptably insulated from the supply circuit before returning the product to the customer.

LEAKAGE TEST(FOR SERVICE ENGINEERS IN THE U.S.A)

Before returning the unit to the user, perform the following safety checks :

1. Inspect all lead dress to make certain that leads are not pinched or that hardware is not lodged between the chassis and other metal parts in the unit.
2. Be sure that any protective devices such as nonmetallic control knobs, insulating fish-papers, cabinet backs, adjustment and compartment covers or shields, isolation resistor-capacity networks, mechanical insulators, etc. Which were removed for the servicing are properly re-installed.
3. Be sure that no shock hazard exists ; check for leakage current using Simpson Model 229 Leakage Tester, standard equipment item No. 21641, RCA Model WT540A or use alternate method as follows : Plug the power cord directly into a 120 volt AC receptacle (do not use an Isolation Transformer for this test). Using two clip leads, connect a 1500 ohms, 10watt Resistor paralleled by a 0.15uF capacitor, in series with all exposed metal cabinet parts and a known earth ground, such as a water pipe or conduit. Use a VTVM or VOM with 1000 ohms per volt, or higher sensitivity to measure the AC voltage drop across the resistor. (See diagram) Move the resistor connection to each exposed metal part having a return path to the chassis (antenna, metal, cabinet, screw heads, knobs and control shafts, escutcheon, etc.) and measure the AC voltage drop across the resistor. (This test should be performed with the 0.35 volt RMS or more is excessive and indicates a potential shock hazard which must be corrected before returning the unit to the owner.

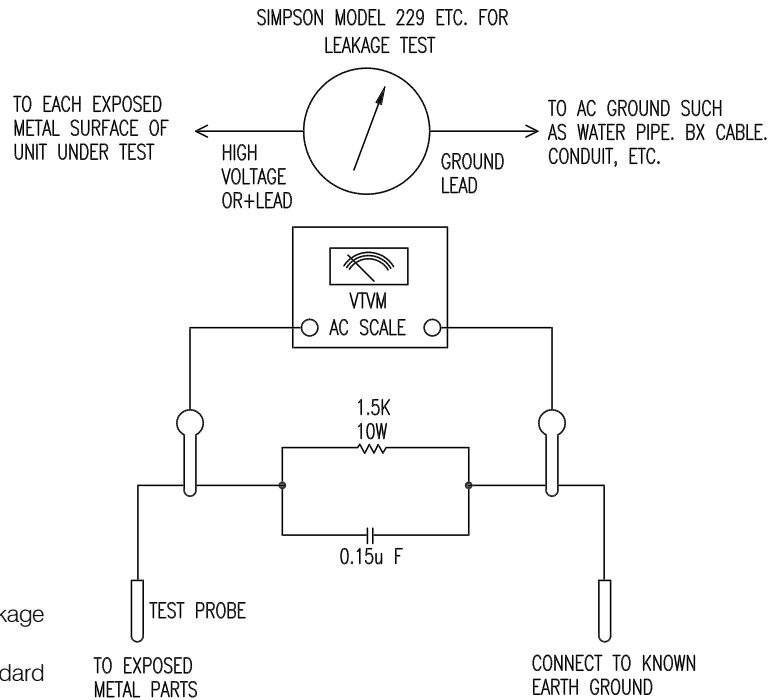

HK 3480 TECHNICAL SPECIFICATIONS

Audio Section

Stereo Mode	
Continuous Average Power (FTC)	
120 Watts per channel, 20Hz–20kHz	
@ < 0.07% THD, both channels driven into 8 ohms	
150 Watts per channel, 20Hz–20kHz	
@ < 0.2% THD, both channels driven into 4 ohms	
Input Sensitivity/Impedance	
Linear (High Level)	200mV/47k ohms
Signal-to-Noise Ratio (IHF-A)	95dB
Frequency Response	
@ 1W (+0dB, -3dB)	10Hz – 110kHz
High Instantaneous Current Capability (HCC)	±45 amps
Transient Intermodulation Distortion (TIM)	Unmeasurable
Rise Time	16µsec
Slew Rate	40V/µsec

Depth measurement includes knobs, buttons and terminal connections.

Height measurement includes feet and chassis.

All features and specifications are subject to change without notice.

Harman Kardon and Power for the Digital Revolution are registered trademarks of Harman International Industries, Incorporated.

FM Tuner Section

Frequency Range	87.5 – 108MHz
Usable Sensitivity	IHF 1.12µV/13.5dB
Signal-to-Noise Ratio	Mono/Stereo 73/72dB
Distortion	Mono/Stereo 0.3/0.4%
Stereo Separation	40dB @ 1kHz
Selectivity	±400kHz, 65dB
Image Rejection	>80dB
IF Rejection	>100dB
Tuner Output Level	1kHz, ±100kHz, Dev 500mV

AM Tuner Section

Frequency Range	520 – 1720kHz
Signal-to-Noise Ratio	>40dB
Usable Sensitivity	Loop 500µV/M
Distortion	1kHz, 50% Mod 0.8%
Selectivity	±10kHz, >25dB

Video Section

Television System	NTSC/PAL/SECAM
Signal Format	Composite
Input Level	1Vp-p
Input Impedance	75 ohms, unbalanced
Sync Polarity	Negative
Output Level	1Vp-p
Output Impedance	75 ohms, unbalanced
Video Frequency Response	10Hz – 10MHz

General

Power Requirement	AC 120V/60Hz
Power Consumption	3W standby, 280W maximum (both channels driven)
Dimension (Max)	(Product) (Shipping)
Width	17.4 inches (442mm) 21.5 inches (545mm)
Height	6.6 inches (168mm) 9.9 inches (251mm)
Depth	15 inches (382mm) 17.9 inches (455mm)
Weight	23.0 lb (10.44kg) 27.3 lb (12.39kg)

FRONT-PANEL CONTROLS

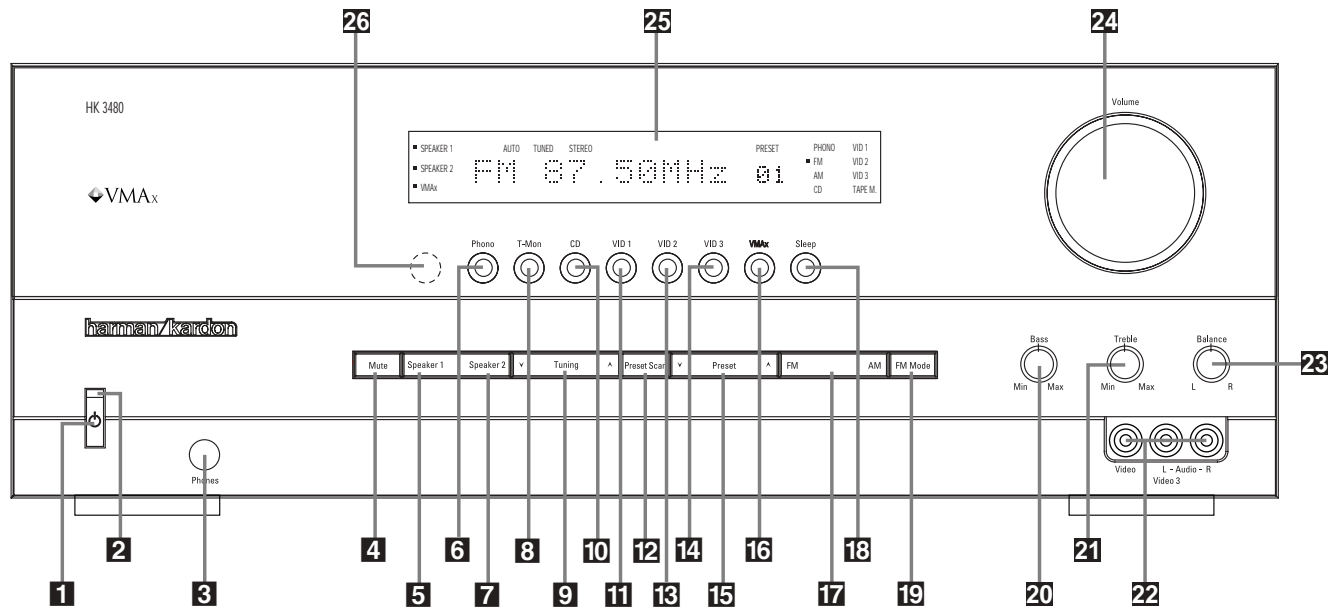

NOTE: To make it easier to follow the instructions that refer to this illustration, a larger copy may be downloaded from the Product Support section for this product at www.harmankardon.com.

- 1** System Power Control
- 2** Power Indicator
- 3** Headphone Jack
- 4** Mute
- 5** Speaker 1 Selector
- 6** Phono Input Selector
- 7** Speaker 2 Selector
- 8** T-Mon Input Selector
- 9** Tuning Button
- 10** CD Input Selector
- 11** Video 1 Input Selector
- 12** Preset Scan
- 13** Video 2 Input Selector
- 14** Video 3 Input Selector
- 15** Preset Selector
- 16** VMAx Selector
- 17** FM/AM Selector
- 18** Sleep Button
- 19** FM Mode Selector
- 20** Bass Control
- 21** Treble Control
- 22** Video 3 Audio/Video Input
- 23** Balance Control
- 24** Volume Control
- 25** Information Display
- 26** Remote Sensor Window

1 System Power Control: Press this button to turn on the HK 3480; press it again to turn the unit off. The **Power Indicator 2** above the switch will initially turn red as the HK 3480 performs a self-check, and it will change to blue when the unit is on and ready for use.

2 Power Indicator: This LED will light in amber when the unit is in the Standby mode to signal that the unit is ready to be turned on. When the unit is turned on, the indicator will briefly turn red, and then change to blue. A red indicator during normal operation means that the unit is in the Protect mode, and should be turned off and then checked for a possible speaker-wire short circuit.

3 Headphone Jack: This jack may be used to listen to the HK 3480's output through a pair of headphones. Be certain that the headphones have a standard 1/4" stereo phone plug.

4 Mute: Press this button to momentarily silence the speaker output of the HK 3480. The message **MUTE** will flash in the **Main Information Display B**, and the **Mute Indicator K** will blink.

5 Speaker 1 Selector: Press this button to turn the speakers connected to the **Speaker 1 Output Terminals 13** on or off.

6 Phono Input Selector: Press this button to select the output of a turntable that is connected to the **Phono Inputs 2**.

7 Speaker 2 Selector: Press this button to turn the speakers connected to the **Speaker 2 Output Terminals 14** on or off.

8 T-Mon Input Selector: Press this button to listen to the output of a tape recorder connected to the **Tape Monitor Inputs 4**. The dot to the left of the **Tape Monitor Input Indicator D** will flash to indi-

cate that the input source is being monitored when the HK 3480 is connected to a three-head tape deck or another unit with off-head playback. See page 15 for more information on monitoring tape recordings.

9 Tuning Button: Press the left side of the button to tune lower-frequency stations and the right side of the button to tune higher-frequency stations. When a station with a strong signal is tuned, the **Tuned Indicator I** will light. A brief (1/2-second) press of the button will manually tune to the next frequency increment, while pressing and holding the button for a longer period will automatically tune to the next station with a signal strong enough for acceptable reception.

10 CD Input Selector: Press this button to listen to the output of a CD player connected to the **CD Audio Inputs 3**.

FRONT - PANEL CONTROLS

11 Video 1 Input Selector: Press this button to listen to and/or view the output of a device connected to the Video 1 Inputs **6**.

12 Preset Scan: Press this button to automatically scan through the stations that have been programmed in the HK 3480's memory. The tuner will play five seconds of each station before moving to the next preset station. To stop the scan when the desired station is heard, press the button again. If no preset stations have been programmed into the HK 3480's memory, the message **PRESET** will flash in the Main Information Display **B** when this button is pressed. (See page 15 for more information on the tuner memory system.)

13 Video 2 Input Selector: Press this button to listen to and/or view the output of a device connected to the Video 2 Inputs **8**.

14 Video 3 Input Selector: Press this button to listen to and/or view the output of a device connected to the Video 3 Inputs **9 22** on either the front or rear panel. If devices are connected to both the front- and rear-panel Video 3 Inputs **9 22**, then the device connected to the rear-panel Video 3 Inputs **9** will be selected first, as indicated by the dot to the left of the Video 3 Input Indicator **D** being steadily lit. To select the device connected to the front-panel Video 3 Inputs **22**, press the Video 3 Input Selector **14** again so that the dot to the left of the Video 3 Input Indicator **D** flashes. Each subsequent press of the Video 3 Input Selector **14** will toggle between the front and rear Video 3 Inputs **9 22**.

15 Preset Selector: Press this button to step up or down through the list of stations that has been entered into the preset memory. If no preset stations have been programmed into the HK 3480's memory, the message **PRESET** will flash in the Main Information Display **B** when this button is pressed. (See page 15 for more information on tuner programming.)

16 VMAx Selector: Press this button to engage VMAx processing of a stereo input. The VMAx Mode Indicator **A** will light, and you will notice a wider, more spacious sound field. In order to obtain maximum benefit, you should be seated midway between the two loudspeakers, and the same distance from the speakers as the speakers are from each other. The speakers must be placed facing parallel and evenly with each other so that their baffles are in the same plane. Press the button again to return to Stereo mode.

17 FM/AM Selector: Press this button to select the tuner as the input to the receiver. Press the left side of this button to select the FM frequency band, or the right side to select the AM frequency band.

18 Sleep Button: Press this button to place the unit in the Sleep mode. Each press of the button selects the amount of time that will remain before the unit automatically goes into the Standby mode, as indicated by the Sleep Timer **C**, in the following order:

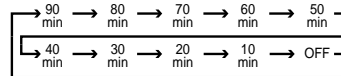

19 FM Mode Selector: Press this button to select the Auto Stereo or Mono mode for FM tuning. In the Auto Stereo mode, the Auto Indicator **J** and Stereo Indicator **H** will light, and stereo reception will be provided when stations are transmitting stereo signals. In the Mono mode, the left and right signals from stereo broadcasts will be mixed together and reproduced through all channels. Select Mono mode for better reception of weak signals.

20 Bass Control: Turn this control to modify the low-frequency output of the left/right channels by as much as ± 10 dB. Set this control to a suitable position for your taste and room acoustics.

21 Treble Control: Turn this control to modify the high-frequency output of the left/right channels by as much as ± 10 dB. Set this control to a suitable position for your taste and room acoustics.

22 Video 3 Audio/Video Inputs: The front-panel Video 3 Audio/Video Inputs **22** are convenient for connecting devices that will only be used temporarily, such as when you wish to view vacation videos directly from the camera. Connect these jacks to the PLAY/OUT jacks of an audio or video device, such as a camcorder or video-game console. To select the front-panel inputs, press the Video 3 Input Selector **14** repeatedly until the dot to the left of the Video 3 Input Indicator **D** flashes. In order to view the video signal of a video device connected to this input, remember to connect the Video Monitor Output **19** to the video input of your TV or video display.

23 Balance Control: Turn this control to change the relative volume for the front left/right channels.

24 Volume Control: Turn the knob clockwise to increase volume, counterclockwise to decrease volume. When the unit has been muted by pressing the Mute Button **4 R**, the message **MUTE** will flash in the Main Information Display **B**, and the Mute Indicator **K** will blink.

25 Information Display: This display delivers messages and status indications to help you operate the receiver.

26 Remote Sensor Window: The sensor behind this window receives infrared signals from the remote control. Aim the remote at this area and do not block or cover it unless an external remote sensor is installed.

FRONT-PANEL INFORMATION DISPLAY

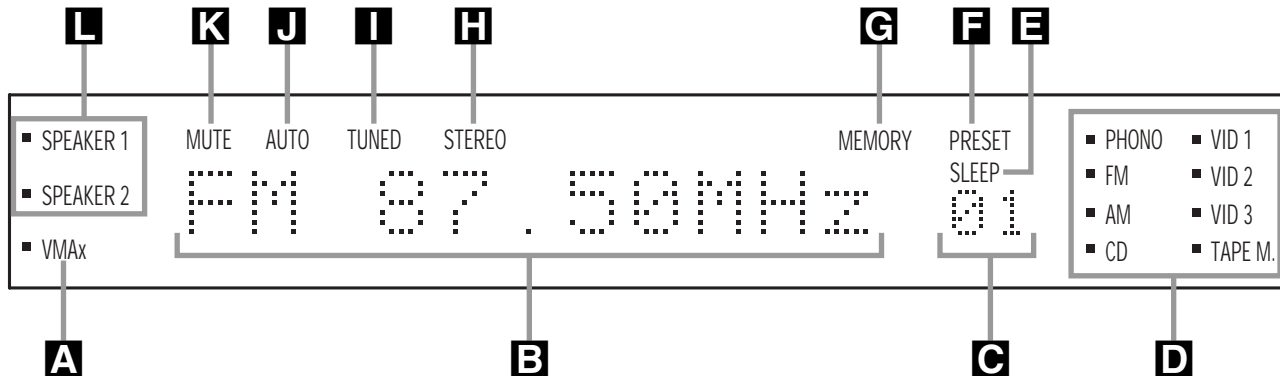

NOTE: To make it easier to follow the instructions that refer to this illustration, a larger copy may be downloaded from the Product Support section for this product at www.harmankardon.com.

- A** VMAx Mode Indicator
- B** Main Information Display
- C** Preset Number/Sleep Timer
- D** Input Indicators
- E** Sleep Indicator
- F** Preset Indicator
- G** Memory Indicator
- H** Stereo Indicator
- I** Tuned Indicator
- J** Auto Indicator
- K** Mute Indicator
- L** Speaker Selection Indicators

A VMAx Mode Indicator: This indicator lights when the VMAx mode is in use. (See page 14 for a description of the VMAx Mode.)

B Main Information Display: This display shows messages relating to the status, input source, tuner or other aspects of the HK 3480's operation.

C Preset Number/Sleep Timer: When the tuner is in use, these numbers indicate the specific preset memory location in use. (See page 15 for more information on preset stations.) When the Sleep function is in use, these numbers show how many minutes remain before the unit goes into the Standby mode.

D Input Indicators: The dot to the left of the name of the device that is currently the source input for the HK 3480 will light.

When the device connected to the **Tape Monitor Inputs 4** has been selected, the dot to the left of the **Tape Monitor Input Indicator D** will flash to indicate that you are hearing the signal the HK 3480 is receiving from the device connected to the **Tape**

Monitor Inputs 4. The dot to the left of the **Input Indicator D** for the last-selected source input will remain lit. See page 15 for more information on monitoring tape recordings.

E Sleep Indicator: This indicator lights when the Sleep function is in use. The numbers in the Preset Number/Sleep Timer Indicators will show the minutes remaining before the HK 3480 goes into the Standby mode. (See page 14 for more information on the Sleep function.)

F Preset Indicator: This indicator lights when the tuner is in use to show that the **Preset Number/Sleep Timer C** is showing the station's preset memory number. (See page 15 for more information on tuner presets.)

G Memory Indicator: This indicator flashes when entering presets and other information into the tuner's memory.

H Stereo Indicator: This indicator lights when an FM station is being tuned in stereo.

I Tuned Indicator: This indicator lights when a station is being received with sufficient signal strength to provide acceptable listening quality.

J Auto Indicator: This indicator lights when the tuner's Auto Stereo mode is in use.

K Mute Indicator: This indicator flashes to remind you that the HK 3480's output has been silenced by pressing the **Mute Button 4 R**. Press the Mute button again to return to the previously selected output level.

L Speaker Selection Indicators: The dot to the left of the indicator for each speaker pair will light when that pair is active. Press the **Speaker 1 5** or **Speaker 2 7** selectors to activate either or both pairs of speakers.

REAR-PANEL CONNECTIONS

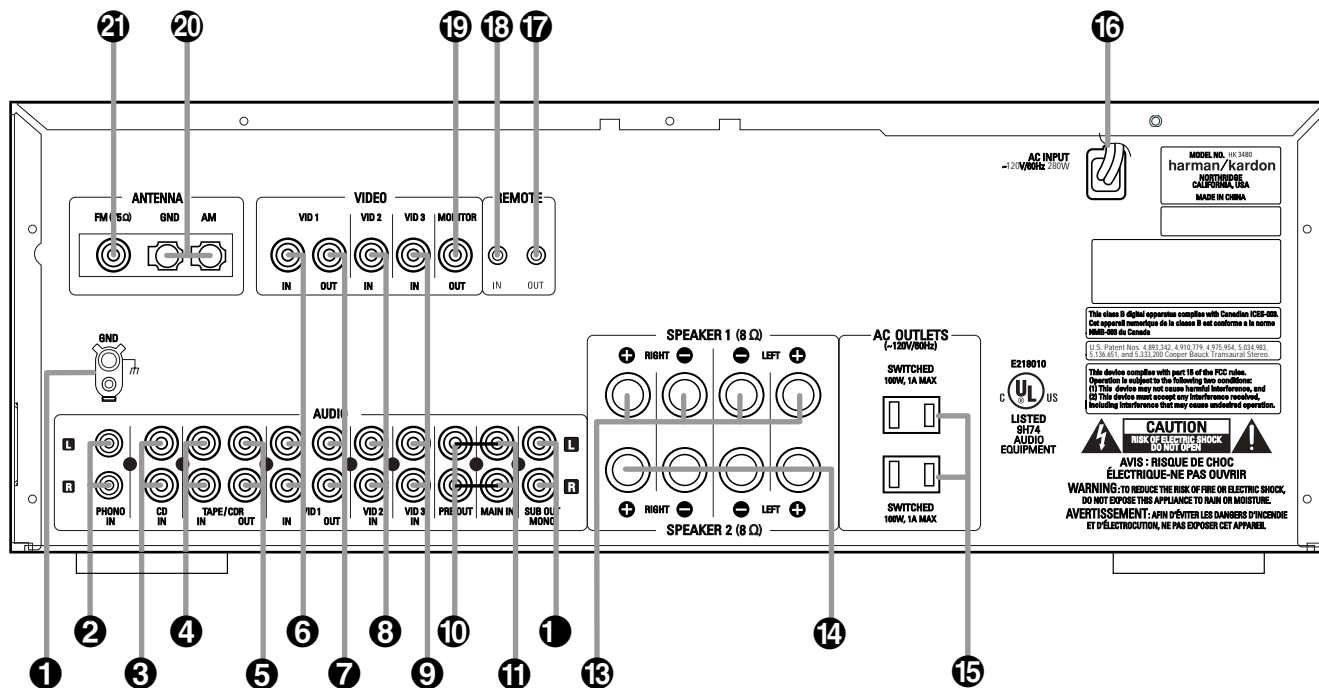

NOTE: To make it easier to follow the instructions that refer to this illustration, a larger copy may be downloaded from the Product Support section for this product at www.harmankardon.com.

- 1 Phono Ground
- 2 Phono Inputs
- 3 CD Audio Inputs
- 4 Tape Monitor Play/In
- 5 Tape Monitor Record/Out
- 6 Video 1 Audio/Video Play/In
- 7 Video 1 Audio/Video Record/Out
- 8 Video 2 Audio/Video Inputs
- 9 Video 3 Audio/Video Inputs
- 10 Preamp Out
- 11 Main In
- 13 Speaker 1 Terminals
- 14 Speaker 2 Terminals
- 15 Accessory Outlets
- 16 Power Cable
- 17 Remote IR Out
- 18 Remote IR In
- 19 Video Monitor Output
- 20 AM Antenna
- 21 FM Antenna

1 Phono Ground: Connect the ground wire from a turntable to this terminal to reduce system hum.

2 Phono Inputs: Connect the outputs of your turntable or tonearm to these jacks. Only Moving Magnet (MM)-type cartridges may be used.

3 CD Audio Inputs: Connect these jacks to the output of a compact disc player or CD changer.

4 Tape Monitor Play/In: Connect these jacks to the Play/Out jacks of an audio recorder.

5 Tape Monitor Record/Out: Connect these jacks to the Rec/In jacks of an audio recorder.

NOTE: When these jacks are connected to a three-head recorder or another device with off-head playback, it will be possible to monitor the source being recorded.

6 Video 1 Audio/Video Play/In: Connect these jacks to the PLAY/OUT jacks of an audio or video device, such as a VCR or DVD player. In order to view the video signal of a video device connected to this input, remember to connect the **Video Monitor Output 19** to the video input of your TV or video display.

7 Video 1 Audio/Video Record/Out: Connect these jacks to the Rec/In jacks of an audio or video recorder.

8 Video 2 Audio/Video Inputs: Connect these jacks to the PLAY/OUT jacks of an audio or video device, such as a VCR or DVD player. In order to view the video signal of a video device connected to this input, remember to connect the **Video Monitor Output 19** to the video input of your TV or video display.

9 Video 3 Audio/Video Inputs: Connect these jacks to the PLAY/OUT jacks of an audio or video device, such as a VCR or DVD player. In order to view the video signal of a video device connected to this input, remember to connect the **Video Monitor Output 19** to the video input of your TV or video display.

10 Preamp Out: These jacks provide an output for the left and right channels to an optional external amplifier. In normal operation, unless an external power amplifier is used, the jumper pins should remain connected between these jacks and the **Main In Jacks 11**.

11 Main In: These jacks are the input to the HK 3480's power amplifier. Unless an external power amplifier is used, the jumper pins should remain connected between these jacks and the **Preamp Out Jacks 10**.

REAR-PANEL CONNECTIONS

11 Subwoofer Out: Connect these jacks to the line-level inputs of a powered subwoofer. If an external subwoofer amplifier is used, connect these jacks to the subwoofer amplifier inputs. When a single, mono subwoofer is used, or if the subwoofer or its amplifier has only a single line-level input jack, make the connection to the bottom jack on the HK 3480.

13 Speaker 1 Terminals: Connect these terminals to the appropriate terminals on your speakers.

14 Speaker 2 Terminals: Connect these terminals to the appropriate terminals on your speakers.

15 Accessory Outlets: These outlets may be used to power low-current-draw devices such as CD players or cassette decks. The power to these outlets remains on as long as the receiver itself is on. When the receiver is placed in the Standby mode, power to these outlets is removed.

NOTE: The power consumption of the devices plugged into these outlets should not exceed 100 watts.

16 Power Cable: Connect the AC plug to a non-switched AC wall output.

17 Remote IR Out: This connection permits the IR sensor in the receiver to serve other remote-controlled devices. Connect this jack to the "IR In" jack on Harman Kardon (or other compatible) equipment.

18 Remote IR In: If the HK 3480's front-panel IR sensor is blocked due to cabinet doors or other obstructions, an external IR sensor may be used. Connect the output of the sensor to this jack.

19 Video Monitor Output: Connect this jack to the composite video input of your TV or video display device. Doing so will enable you to view the video signal of a properly connected video source device, when that source input is selected. When an audio-only source is selected, the **Video Monitor Output 19** will not transmit a video signal.

20 AM Antenna: Connect the AM loop antenna supplied with the receiver to these terminals. If an external AM antenna is used, make connections to the **AM** and **GND** terminals in accordance with the instructions supplied with the antenna.

21 FM Antenna: Connect an indoor or external FM antenna to this terminal.

REMOTE CONTROL FUNCTIONS

- A** Main Power On
- B** Main Power Off
- C** Source Selectors
- D** Preset Up/Down
- E** Transport Controls
- F** Disc Skip
- G** Sleep Button
- H** Dimmer Button
- I** Tuning
- J** Direct Button
- K** Numeric Keys
- L** Auto Preset
- M** Secondary Control Cover
- N** Clear Button
- O** Memory Button
- P** Master Volume
- Q** Preset Scan Button
- R** Mute Button
- S** FM Mode Button
- T** VMAx Selector
- U** Enter Button
- V** Tuning Up/Down
- W** Speaker 1 Selector
- X** Speaker 2 Selector
- Y** Transmitter Window

NOTES:

- The function names shown here are each button's feature when used with the HK 3480. Most buttons have additional functions when used with other devices. See page 16 for a list of these functions.
- To make it easier to follow the instructions that refer to this illustration, a larger copy may be downloaded from the Product Support section for this product at www.harmankardon.com.

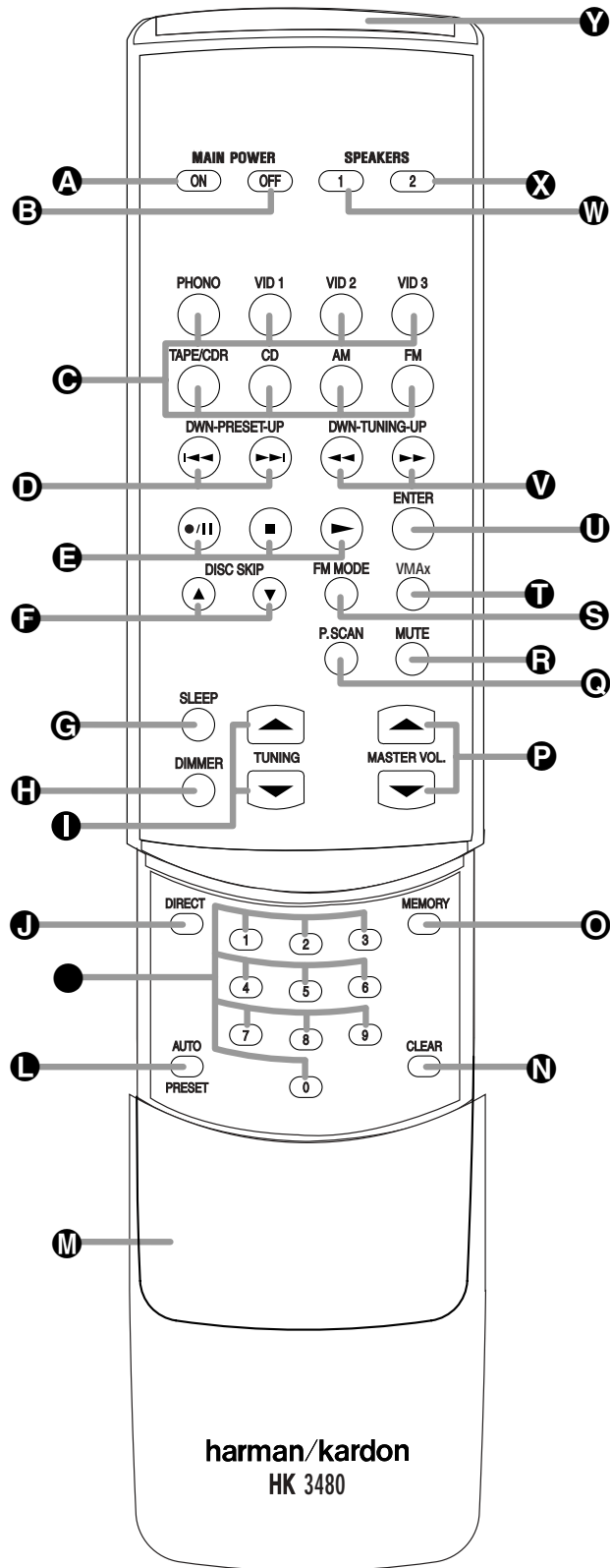

REMOTE CONTROL FUNCTIONS

A Main Power On: When the HK 3480 is in the Standby mode, as indicated by the **Power Indicator**

2 glowing amber, press this button to turn the HK 3480 on.

B Main Power Off: When the HK 3480 is turned on, press this button to place it in the Standby mode. In this condition, the unit is still connected to AC Power.

C Source Selectors: Press these buttons to select an input source for the HK 3480.

NOTE: The first press of the **Video 3 Source Selector C** will select the device connected to the rear-panel **Video 3 Audio/Video Inputs 9**. Press the **Video 3 Source Selector C** again until the dot to the left of the **Video 3 Input Indicator D** flashes to select the device connected to the front-panel **Video 3 Audio/Video Inputs 22**. Each additional press of the **Video 3 Source Selector C** will toggle between the front- and rear-panel **Video 3 Audio/Video Inputs 9 22**.

D Preset Up/Down: When the tuner is in use, these buttons scroll through the stations that have been programmed into the HK 3480's memory. These buttons also control the track Skip Up/Down on compatible Harman Kardon compact disc players/changers.

E Transport Controls: These buttons are used to control the Play, Stop, Pause and Record functions on compatible Harman Kardon CD/DVD players/changers and CD recorders.

F Disc Skip: These buttons do not have any functions when controlling the HK 3480, but they operate the Disc Skip functions of compatible Harman Kardon CD/DVD changers.

G Sleep Button: Press this button to place the unit in the Sleep mode. Each press of the button selects the amount of time that will remain before the unit will automatically go into the Standby mode, as shown in the **Sleep Timer C**, in the following order:

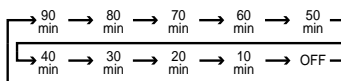

H Dimmer Button: Press this button to dim the front-panel displays and indicators. The first press of the button will dim the displays to one-half normal brightness and turn off the blue light inside the **Volume Control 24**, but the **Power Indicator 2** will remain lit. The next press of the **Dimmer Button 16** will turn off all displays, including the light inside the **Volume Control 24**, but the **Power Indicator 2** will remain lit to remind you that the unit is turned on. Press the button again to return the display to normal brightness. When the panel is dimmed, it will

return to normal brightness after the unit is turned off, then on again.

I Tuning: Press these buttons to tune up or down through a selected frequency band. A brief (1/2-second) press of the button will manually tune to the next frequency increment, while pressing and holding the button for a longer period will automatically tune to the next station with a signal strong enough for acceptable reception.

J Direct Button: Press this button to select a radio station by entering its frequency using the **Numeric Keys K**. (See page 14 for more information.)

K Numeric Keys: These buttons serve as a 10-button numeric keypad to enter tuner preset positions or to tune stations directly.

L Auto Preset: When the tuner and FM band have been selected, this button may be used to automatically program the tuner presets for all active stations. To start the auto preset scan, press and hold the button. Note that the **Memory G** and **Preset F** indicators will flash. After a few seconds, the tuner will start to "look" for active stations, as shown by increasing frequency numbers in the **Main Information Display B**.

Release the button and note that the tuner will briefly stop at each active station and add a preset number to the memory. If the FM tuner finds fewer than 30 FM stations with acceptable signal strength, the Auto Preset tuning will scan two more cycles or until the remaining vacant preset memory spaces have been filled with those found in the first scan. The scan will stop when all 30 preset memory spaces have been filled or when three scans through the band have been completed.

M Secondary Control Cover: This sliding cover normally is in the "up" position so that it hides the secondary controls. To access these controls, place your thumb on the small recessed area at the top center of the control, and gently press the cover down and toward you.

N Clear Button: This button is used to clear preset memory information for the HK 3480's tuner. (See page 15 for more information on tuner presets.)

O Memory Button: Press this button to open a memory position that stores a preset location for the HK 3480's tuner. (See page 15 for more information on tuner presets.)

P Master Volume: Press these buttons to raise or lower the HK 3480's volume.

Q Preset Scan Button: Press this button to automatically scan through the list of stations that are programmed into the HK 3480's tuner memory. When the button is pressed, each preset station will play

for five seconds before the next station is selected. Press the button again when the desired station is heard, to stop the preset scan.

R Mute Button: Press this button to momentarily silence the HK 3480.

S FM Mode Button: Press this button when the tuner is in use in the FM band to switch to monaural reception if the station is weak and noisy. (See page 14 for more information.)

T VMaX Selector: Press this button to engage VMaX processing of a stereo input. The **VMaX Mode Indicator A** will light, and you will notice a wider, more spacious sound field. In order to obtain maximum benefit, you should be seated midway between the two loudspeakers, and the same distance from the speakers as the speakers are from each other. The speakers must be placed facing parallel and evenly with each other so that their baffles are in the same plane. Press the button again to return to Stereo mode.

U Enter Button: This button has no function on the HK 3480, but may be used as the Enter key for a compatible Harman Kardon DVD Player or as the Random Play button for a compatible CD Player. See page 16 for more information on using the remote to control other devices.

V Tuning Up/Down: When the tuner is in use, these buttons will tune up or down through the selected frequency band. A brief (1/2-second) press of the button will manually tune to the next frequency increment, while pressing and holding the button for a longer period will automatically tune to the next station with a signal strong enough for acceptable reception. These buttons will also control Fast Forward and Fast Reverse (or Rewind) for compatible Harman Kardon compact disc players/changers.

W Speaker 1 Selector: Press this button to turn the speakers connected to the **Speaker 1 Output Terminals 13** on or off.

X Speaker 2 Selector: Press this button to turn the speakers connected to the **Speaker 2 Output Terminals 14** on or off.

Y Transmitter Window: Point this area of the remote toward the receiver when using the remote.

TROUBLESHOOTING GUIDE

This unit is designed for trouble-free operation. Most problems users encounter are due to operating errors. So, if you have a problem, first check this list for a possible solution. If the problem persists, consult your authorized Harman Kardon service center.

If the problem is . . .	Make sure that the . . .
No lights appear when POWER button is pressed	Unit is plugged into a live outlet
No sound is heard	Unit has not been muted Correct input function selector button has been pressed Volume is turned up Speakers have been turned on using the Speaker Selectors Headphones are not in use Jumper pins are in place, unless an external amplifier is in use
No output from one or more channels	Cables are not defective: check/replace speaker cables
Tuner sound has a large amount of interference, or The "Stereo" display is not illuminated, or Tuner sound distorts and/or volume level is too low	Antenna is properly connected Antenna is properly located Antenna is set in the proper direction Antenna is adequate to receive the desired station
Tuner is intermittent or continuously buzzing or hissing	Unit is away from fluorescent lights, TVs, motors and other electrical appliances
Remote does not function correctly	Batteries are not weak, and replace them if necessary Room lighting is not overly bright
Cassette or CD sounds distorted	Cassette deck or CD player has not been plugged into the Phono Input ② (only use the outputs of a turntable or tone arm with the Phono Input ②)
Turntable sounds distorted	Turntable has been plugged into the Phono Input ② , as the other inputs are not compatible with turntable signal levels
No video image	Video source unit's video output is properly connected, the source is turned on and the correct video input on the HK 3480 has been selected Video Monitor Output ①⑨ is connected to a TV or video display, and that the TV is turned on and the proper input on the TV has been selected

Memory Backup

This product is equipped with a non-volatile EEPROM (Electrically Erasable and Programmable Read-Only Memory) that preserves tuner presets and system configuration information without the unit being connected to a main power source for any prolonged period of time.

Processor Reset

In the rare case where the unit's operation or the displays seem abnormal, the cause may involve the erratic operation of the system's memory or microprocessor.

To correct this problem, first unplug the unit from the AC wall outlet and wait at least thirty minutes. After the pause, reconnect the AC power cord and check the unit's operation. If the system still malfunctions, a system reset may clear the problem. To reset the system, first turn the HK 3480 off by pressing the System Power Control. Next, press and hold the front-panel Mute Button for at least 4 seconds. The Main Information Display will briefly show the word RESET, and then return to normal operation. When the system is reset in this fashion, all tuner presets will be lost and must be reentered. If the system is still operating incorrectly, there may have been an electronic discharge or severe AC line interference that has corrupted the memory or microprocessor. If these steps do not solve the problem, consult an authorized Harman Kardon service center.

AMPLIFIER SECTION BIAS ADJUSTMENT

Measurement condition

; No input signal or volume position is minimum.

Standard value

; Ideal current = 48mA (±5%)

; Ideal DC Voltage = 21.12mV (±5%)

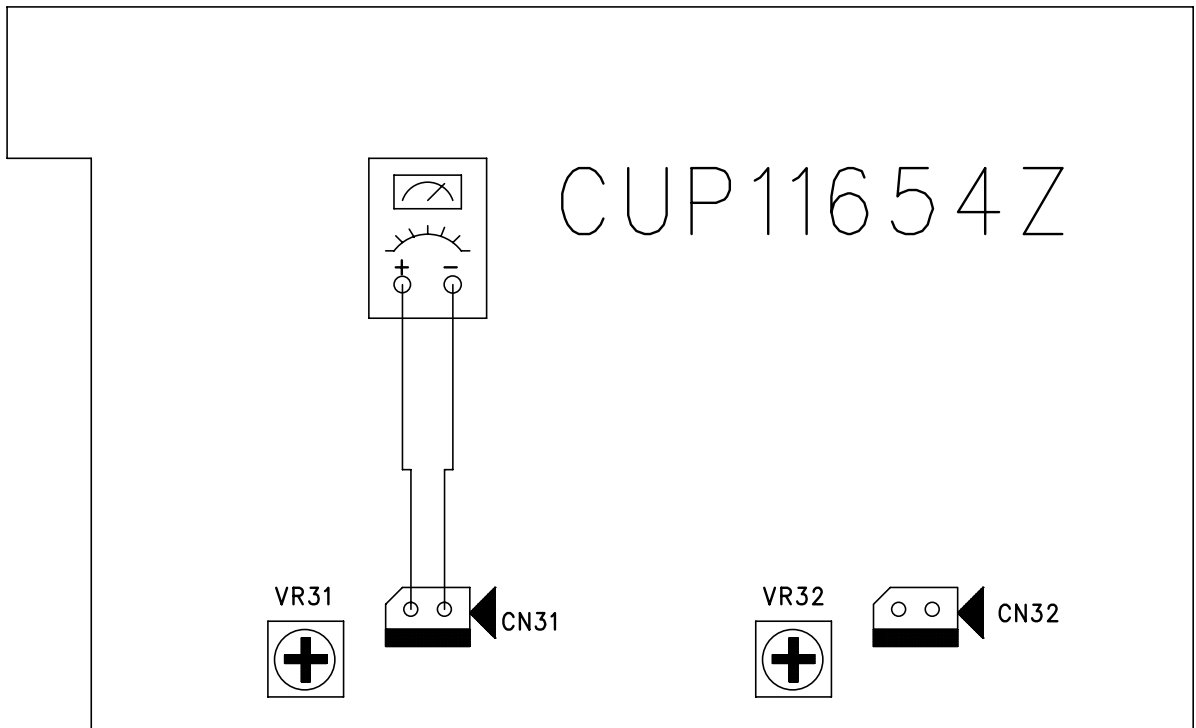

DC VOLTMETERConnect to CN31 , CN32

NO.	CHENNEL	ADJUST FOR	ADJUSTMEØR
1	L CH	21.12mV (±5%)	VR31
2	R CH	21.12mV (±5%)	VR32

harman/kardon

Service Bulletin

Service bulletin # H/K2003-10 December 2003

Warranty labor rate: MAJOR repair

To: All harman/kardon Service Centers

Models: AVR130, AVR230, AVR330, HK3380, HK3480

Subject: Volume Level Changes

On early versions of the AVR130, AVR230, AVR330, HK3380, HK3480, when the volume control is turned, the volume level and display may be erratic, and not track accurately, or the level may progress in an unintended direction. This may happen on a random basis and depends on where the volume control knob is positioned after a volume adjustment. During a running production change, new volume encoders were installed.

In the event you receive an AVR model listed above with the complaint “The volume control on my receiver does not track accurately when turned”, perform the following procedure:

REPLACE VR74 (AVR130/230/330) or VR81 (HK3380/3480) VOLUME ENCODER

Note: It is important that the various screws do not get mixed up and inserted in other locations upon reassembly. Make note or label each removed screw set; keep them apart from other screw sets.

- 1) Remove the top cover, (13) Phillips screws.
- 2) Remove the volume, bass, treble and balance knobs by pulling them straight out and off. If a tool is necessary for removal of the smaller knobs, make sure the jaws are insulated to avoid knob damage.
- 3) Remove the (10) Phillips screws holding the front panel ass'y to the chassis: (6) at the bottom and (4) at the sides.
- 4) Cut all plastic cable ties that would prevent you detaching the front panel ass'y from the chassis. Draw a diagram if necessary, for a location reminder, to aid reassembly.
- 5) Unplug connector CN15 (6 cond) or CN89 (7 cond) at the left side of the unit. See below.
- 6) Remove single ground screw at the left side of the unit, near CN15 or CN89. (Black wire)
- 7) Unplug connector CN72 (32 cond) or CN81 (20 cond) on the DSP PCB, coming from the top of the front panel ass'y. See below.
- 8) There should now be enough slack in the connecting cables to lift and detach the front panel ass'y from the chassis. Pull the front panel as far away as the remaining connecting wires will allow, enough to tilt and gain access to the rear of the Tone/Volume PCB. See illustration Page 2.
- 9) Remove the (10) screws or (9) screws holding the Tone/Volume PCB to the front panel.
- 10) Detach and pull back the PCB; unplug top connector CN84 (7 cond) or CN83 (4 cond) if necessary.
- 11) Remove and replace VR74 or VR81 (5 soldered pads) with hk part# HSR2A029Z.
- 12) Reassemble in reverse order, taking care to replace all connectors, cable ties, and ground screw.
- 13) Power up receiver, and test volume control to assure setting no longer changes settings by itself, or when the volume knob is tapped.

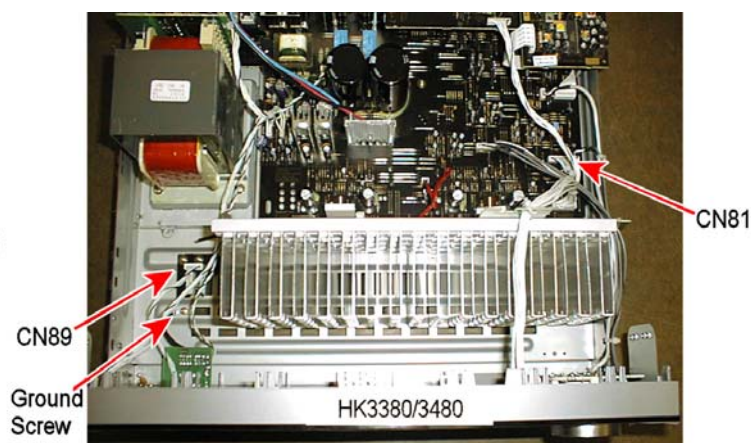
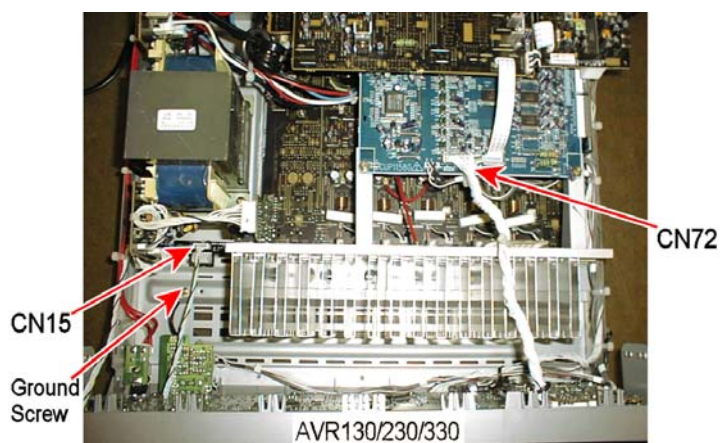

Ready for Volume/Tone PCB removal

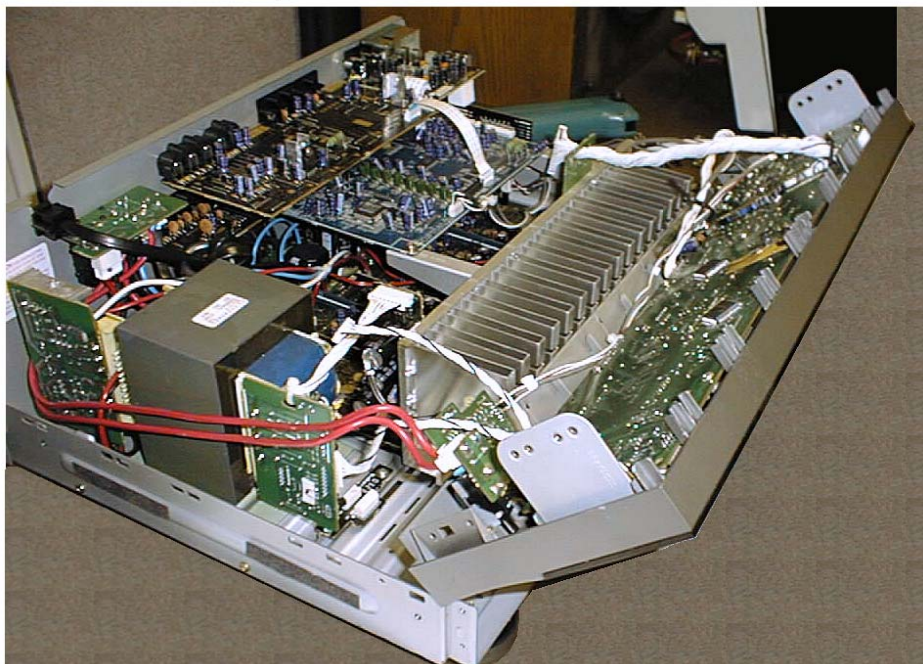

Model	Serial Number 120V	STATUS	ACTION
AVR130	AN0006-01000 to AN0006-13800	Volume control may not track accurately when turned; erratic operation	Change VR74 Rotary encoder
AVR130	AN0006-13801 and above	Modified By Factory	NONE REQUIRED
AVR230	AN0007-01000 to AN0007-11400	Volume control may not track accurately when turned; erratic operation	Change VR74 Rotary encoder
AVR230	AN0007-11401 and above	Modified By Factory	NONE REQUIRED
AVR330	AN0008-01000 to AN0008-08524	Volume control may not track accurately when turned; erratic operation	Change VR74 Rotary encoder
AVR330	AN0008-08525 and above	Modified By Factory	NONE REQUIRED
HK3380	AN0015-01000 to AN0015-02728	Volume control may not track accurately when turned; erratic operation	Change VR81 Rotary encoder
HK3380	AN0015-02729 and above	Modified By Factory	NONE REQUIRED
HK3480	AN0016-01000 to AN0016-01864	Volume control may not track accurately when turned; erratic operation	Change VR81 Rotary encoder
HK3480	AN0016-01865 and above	Modified By Factory	NONE REQUIRED

harman/kardon**Service Bulletin**

Service bulletin # H/K2004-02 April 2004

Warranty labor rate: MINOR repair

To: All harman/kardon Service Centers

Model: HK3380/3480

Subject: Silence During Preset Scan - Upgrade

In the event you receive an HK3380 or HK3480 stereo receiver with the complaint: "When the Preset Scan Function * is activated and the receiver cycles through the list of station presets, there is silence", the unit is in need of a software upgrade.

The unit should be sent to the following authorized service center equipped to perform the software upgrade:

**HARMAN CONSUMER GROUP DISTRIBUTION CENTER
801 S. 75TH AVE.
PHOENIX, AZ. 85043
Attn: Rodney Yee**

Model	Serial Number (120v)	Serial Number (230v)	Status	Action (upgrade)
HK3380	AN0015-01000 to AN0015-04456	AN0017-01000 to AN0017-06100	If Silence During Preset Scan Upgrade is Needed	Upgrade Possible
HK3380	AN0015-04457 and above	AN0017-06101 and above	Modified by Factory	None Required
HK3380	AN0016-01000 to AN0016-03592	AN0018-01000 to AN0018-6100	If Silence During Preset Scan Upgrade is Needed	Upgrade Possible
HK3480	AN0016-035923 and above	AN0018-6101 and above	Modified by Factory	None Required

* Preset Scan: Press this button to automatically scan through the stations that have been programmed in the unit's memory. The tuner will play five seconds of each station before moving to the next preset station. To stop the scan when the desired station is heard, press the button again. If no preset stations have been programmed into the unit's memory, the message *0 PRESET* will flash in the Main Information Display when this button is pressed.

DISASSEMBLY PROCEDURES

<1> TOP-CABINET(21) REMOVAL

1. Remove 13 screws(S1) and then remove the Top-cabinet.

<2> FRONT PANEL ASS'Y REMOVAL

1. Remove the Top-cabinet, referring to the previous step<1>.
2. Disconnect the lead wire(BN71-12P,BN72-5P) on the Tone PCB(38) from connector(CN71,CN72) on the Main PCB(44).
3. Disconnect the lead wire(BN82-7P) on the Front PCB(37) from connector(CN82) on the Main PCB(44).
4. Disconnect the connector(CN81-20P wire assy) on the Front PCB(37) from connector(CN81) on the Main PCB(44).
5. Disconnect the lead wire(BN73-3P) on the Phone PCB(40) from connector(CN73) on the Main PCB(44).
6. Disconnect the lead wire(BN89-7P) on the Front PCB(37) from connector(CN73) on the Download PCB(44).
7. Remove 1 screw(S10) and then lead wire(JW73-2P) on the Phone PCB(40).
8. Remove 1 screw(S10) and then lead wire(JW72-1P) on the Tone PCB(38).
9. Remove 9 screws(S1) and then remove the Front Panel ASS'Y.

<3> TONE PCB(38) REMOVAL

1. Remove the Top-cabinet, referring to the previous step<1>.
2. Remove the Front Panel ASS'Y, referring to the previous step<2>.
3. Pull out the Volume Knob ASS'Y & 3 Rotary Knobs(5).
4. Remove 9 screws(S1,S11) and then remove the Tone PCB(38).
5. Disconnect the lead wire(BN83-4P) from connector(CN83) on the Tone PCB(38).

<4>PHONE PCB(40) REMOVAL

1. Remove the Top-cabinet, referring to the previous step<1>.
2. Remove the Front Panel ASS'Y, referring to the previous step<2>.
3. Remove 2 screws(S2,S3) and then remove the Phone PCB(16).

<5>POWER LED PCB(39) REMOVAL

1. Remove the Top-cabinet, referring to the previous step<1>.
2. Remove the Front Panel ASS'Y, referring to the previous step<2>.
3. Remove 2 screws(S2) and then remove the Power led PCB(39).
4. Disconnect the lead wire(BN84-4P) from connector(CN84) on the Power led PCB(39).

<6>FRONT PCB(37) REMOVAL

1. Remove the Top-cabinet, referring to the previous step<1>.
2. Remove the Front Panel ASS'Y, referring to the previous step<2>.
3. Remove the Tone PCB(38), referring to the previous step<3>.
4. Remove the Phone PCB(40), referring to the previous step<4>.
5. Remove the Power led PCB(39), referring to the previous step<5>.
6. Remove 13 screws(S2) and then remove the Front PCB(37).

<7>TUNER MODULE(34) REMOVAL

1. Remove the Top-cabinet, referring to the previous step<1>.
2. Disconnect the connector(CON1-Card cable) from connector(CN26) on the Main PCB ASS'Y(44).
3. Remove 2 screws(S8) and then remove the Tuner Module(34).

<8>VIDEO PCB(43) REMOVAL

1. Remove the Top-cabinet, referring to the previous step<1>.
2. Disconnect the connector (CN91) on the Main PCB ASS'Y(44) from lead wire(BN91-9P) on the Video PCB(43).
3. Remove 4 screws(S8,S13) and then remove the Video PCB(43).

<9>DOWNLOAD PCB(42) REMOVAL

1. Remove the Top-cabinet, referring to the previous step<1>.
2. Disconnect the connector (CN89) from lead wire(BN89-7P) on the Front PCB(37).
3. Remove 2 screws(S4) and then remove the Download PCB(42).

<10>POWER TRANS(30) REMOVAL

1. Remove the Top-cabinet, referring to the previous step<1>.
2. Disconnect the connector (CN62,CN63,CN64) on the Trans PCB from lead wire(BN62-2P,BN63-3P,BN64-6P) on the Main PCB(44).
3. Remove 4 Trans screws(S9) and then remove the Power Trans(30).

<11>MAIN PCB ASS'Y(44) REMOVAL

1. Remove the Top-cabinet, referring to the previous step<1>.
2. Remove the Power Trans(30), referring to the previous step<10>.
3. Disconnect the connector(CN81-20P wire ass'y) from connector(CN81-7P) on the Front PCB(37).
4. Disconnect the connector(CN82) from lead wire(BN82-7P) on the Front PCB(37).
5. Disconnect the connector(CN71) from lead wire(BN71-12P) on the Tone PCB(38).
6. Disconnect the connector(CN72) from lead wire(BN72-5P) on the Tone PCB(38).
7. Disconnect the connector(CN73) from lead wire(BN73-3P) on the Phone PCB(40).
8. Disconnect the connector(CN91) from lead wire(BN91-9P) on the Video PCB(43).
9. Disconnect the connector(CN26-Card cable) from lead wire(CON1) on the Tuner Module(34).
10. Disconnect the connector(CN61) from Power cord(35).
11. Remove 21 screws(S8-11EA, S13-1EA, S4-2EA, S6-2EA, S15-1EA, S12-3EA, S5-1EA) and then remove the Main PCB ASS'Y(44).

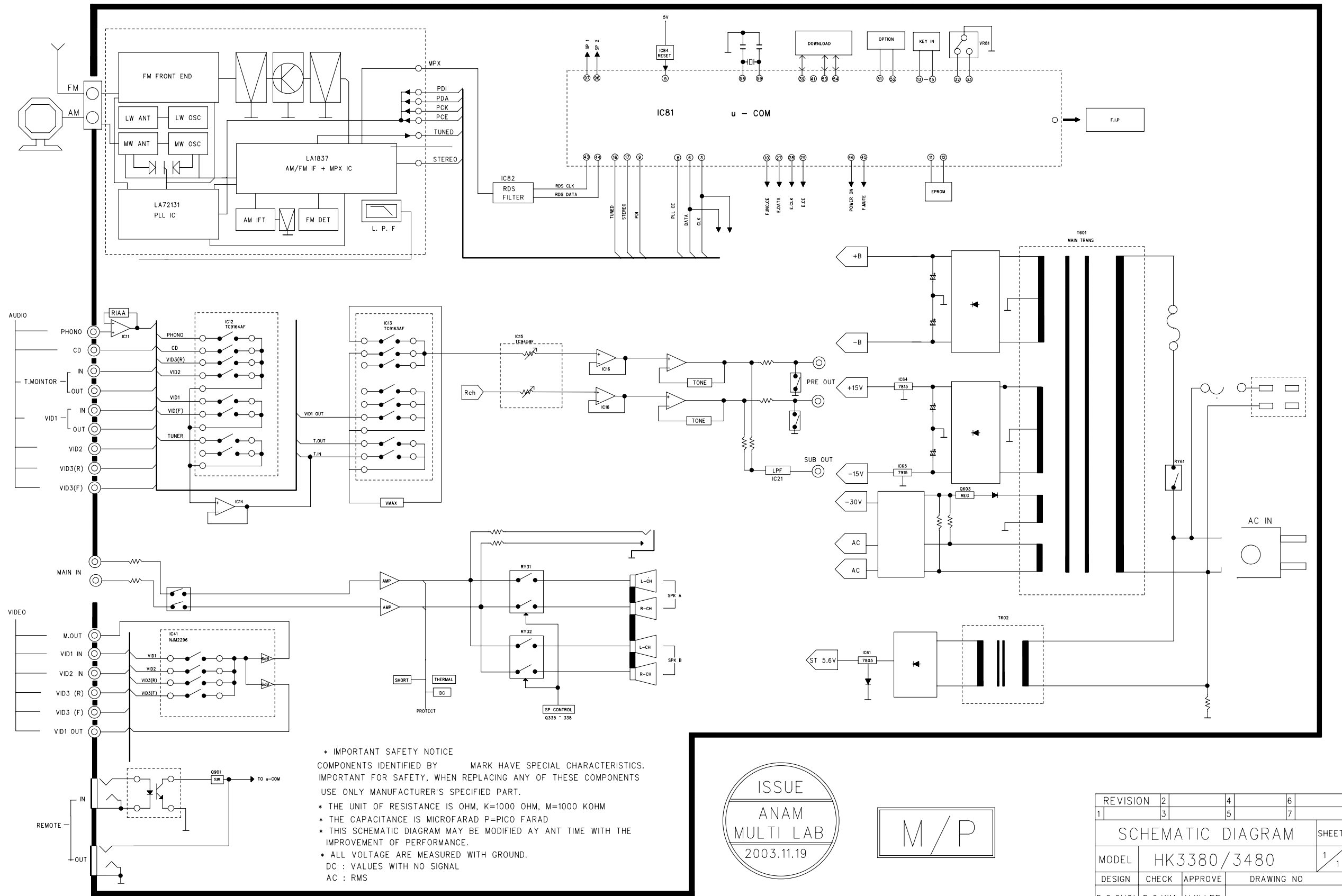

*** IMPORTANT SAFETY NOTICE**
 COMPONENTS IDENTIFIED BY MARK HAVE SPECIAL CHARACTERISTICS. IMPORTANT FOR SAFETY, WHEN REPLACING ANY OF THESE COMPONENTS USE ONLY MANUFACTURER'S SPECIFIED PART.
 * THE UNIT OF RESISTANCE IS OHM, K=1000 OHM, M=1000 KOHM
 * THE CAPACITANCE IS MICROFARAD P=PICO FARAD
 * THIS SCHEMATIC DIAGRAM MAY BE MODIFIED AT ANY TIME WITH THE IMPROVEMENT OF PERFORMANCE.
 * ALL VOLTAGE ARE MEASURED WITH GROUND.
 DC : VALUES WITH NO SIGNAL
 AC : RMS

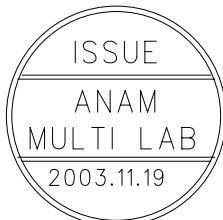

REVISION	2	4	6	
1	3	5	7	
SCHEMATIC DIAGRAM				SHEET
MODEL	HK3380/3480			1/1
DESIGN	CHECK	APPROVE	DRAWING NO	
D.C.CHOI	D.G.KIM	H.W.LEE	1653BCMZ	
03.08.01				

HCA16ML08 - 1 (F.I.P) : FIP1

OUTER DIMENSIONS

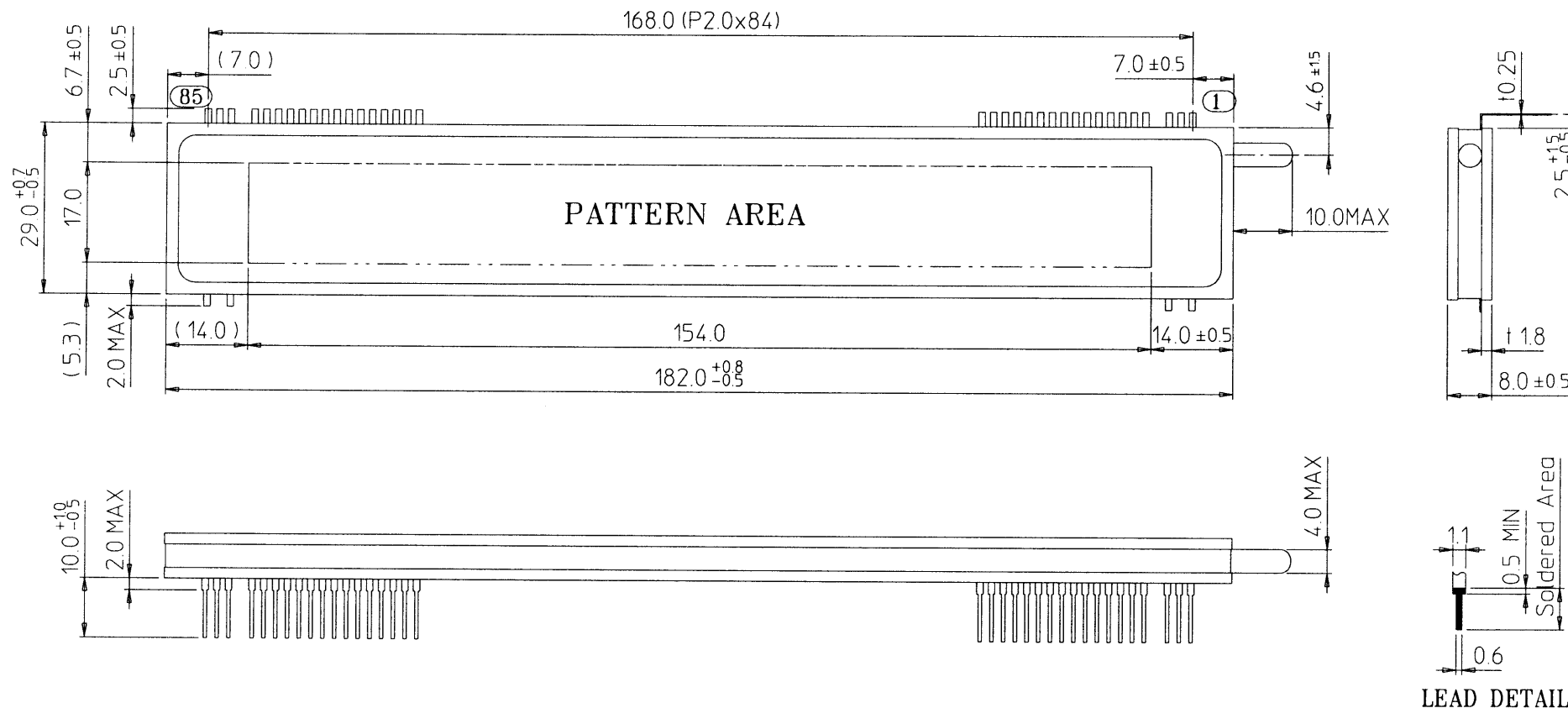

PIN CONNECTION

* TS : Test pin. Be left open if not used.

*Notes

Fn : Filament Pin

NP : No Pin

NC : No connection

PIN NO.	85	84	83	82	81~67	66~20	19	18	17	16	15	14	13	12	11	10	9	8	7	6	5	4	3	2	1
CONNECTION	F2	F2	F2	NP	TS	NP	16G	15G	NC	GR15	GR16	NC	V _{DD}	DIN	CLKB	CSB	RSTB	OSCO	OSCI	V _{EE}	GND	NP	F1	F1	F1

MODEL : HCA-16ML08
 OUTER DIMENSIONS
 Rev. (1) 26-Jun-2003



PATTERN DETAILS

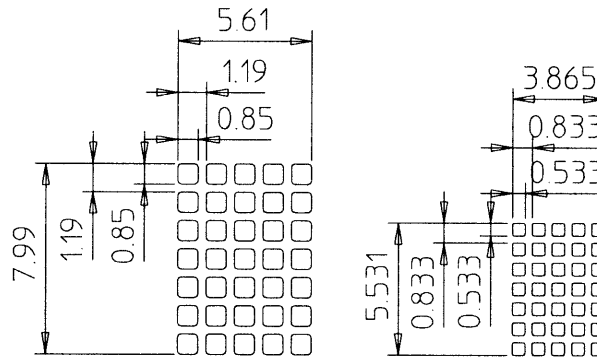
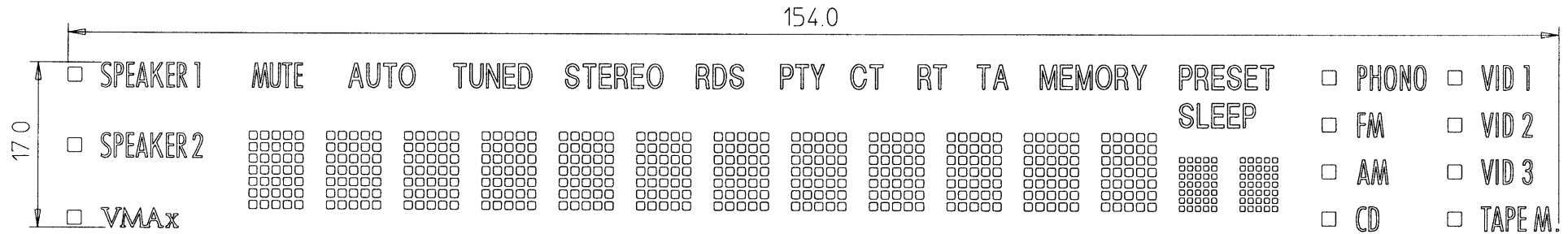

© Color of Illumination ©

- Green (G ; x=0.250,y=0.439) --- All Patterns.

MODEL : HCA-16ML08
 PATTERN DETAILS
 Rev. (1) 26-Jun-2003

GRID ASSIGNMENT

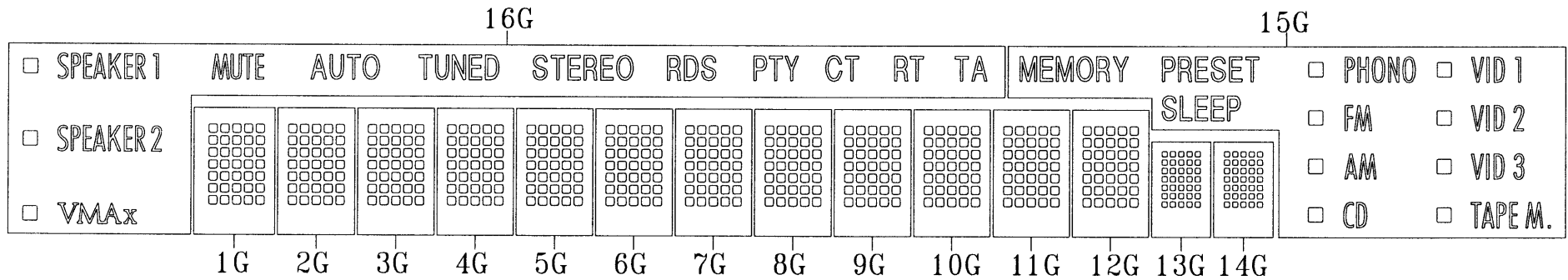

- 1 2 3 4 5
- 6 7 8 9 10
- 11 12 13 14 15
- 16 17 18 19 20
- 21 22 23 24 25
- 26 27 28 29 30
- 31 32 33 34 35

(1G ~ 14G)

MODEL : HCA-16ML08
 GRID ASSIGNMENT
 Rev. (1) 26-Jun-2003



ANODE CONNECTION

	GR1	GR2	GR3	GR4	GR5	GR6	GR7	GR8	GR9	GR10	GR11	GR12	GR13	GR14	GR15	GR16
	1G	2G	3G	4G	5G	6G	7G	8G	9G	10G	11G	12G	13G	14G	15G	16G
SG1	1	1	1	1	1	1	1	1	1	1	1	1	1	1		
SG2	2	2	2	2	2	2	2	2	2	2	2	2	2	2	<input type="checkbox"/> (PHONO)	
SG3	3	3	3	3	3	3	3	3	3	3	3	3	3	3	PHONO	
SG4	4	4	4	4	4	4	4	4	4	4	4	4	4	4	<input type="checkbox"/> (VID 1)	
SG5	5	5	5	5	5	5	5	5	5	5	5	5	5	5	VID 1	
SG6	6	6	6	6	6	6	6	6	6	6	6	6	6	6	<input type="checkbox"/> (FM)	
SG7	7	7	7	7	7	7	7	7	7	7	7	7	7	7	FM	
SG8	8	8	8	8	8	8	8	8	8	8	8	8	8	8	<input type="checkbox"/> (VID 2)	
SG9	9	9	9	9	9	9	9	9	9	9	9	9	9	9	VID 2	
SG10	10	10	10	10	10	10	10	10	10	10	10	10	10	10	SLEEP	
SG11	11	11	11	11	11	11	11	11	11	11	11	11	11	11	PRESET	
SG12	12	12	12	12	12	12	12	12	12	12	12	12	12	12	MEMORY	
SG13	13	13	13	13	13	13	13	13	13	13	13	13	13	13		TA
SG14	14	14	14	14	14	14	14	14	14	14	14	14	14	14		RT
SG15	15	15	15	15	15	15	15	15	15	15	15	15	15	15		CT
SG16	16	16	16	16	16	16	16	16	16	16	16	16	16	16		PTY
SG17	17	17	17	17	17	17	17	17	17	17	17	17	17	17		RDS
SG18	18	18	18	18	18	18	18	18	18	18	18	18	18	18		STEREO
SG19	19	19	19	19	19	19	19	19	19	19	19	19	19	19		TUNED
SG20	20	20	20	20	20	20	20	20	20	20	20	20	20	20		AUTO
SG21	21	21	21	21	21	21	21	21	21	21	21	21	21	21		MUTE
SG22	22	22	22	22	22	22	22	22	22	22	22	22	22	22	<input type="checkbox"/> (AM)	
SG23	23	23	23	23	23	23	23	23	23	23	23	23	23	23	AM	
SG24	24	24	24	24	24	24	24	24	24	24	24	24	24	24	<input type="checkbox"/> (VID 3)	
SG25	25	25	25	25	25	25	25	25	25	25	25	25	25	25	VID 3	
SG26	26	26	26	26	26	26	26	26	26	26	26	26	26	26	<input type="checkbox"/> (CD)	
SG27	27	27	27	27	27	27	27	27	27	27	27	27	27	27	CD	
SG28	28	28	28	28	28	28	28	28	28	28	28	28	28	28	<input type="checkbox"/> (TAPE M.)	
SG29	29	29	29	29	29	29	29	29	29	29	29	29	29	29	TAPE M.	
SG30	30	30	30	30	30	30	30	30	30	30	30	30	30	30		<input type="checkbox"/> (SPEAKER 1)
SG31	31	31	31	31	31	31	31	31	31	31	31	31	31	31		SPEAKER 1
SG32	32	32	32	32	32	32	32	32	32	32	32	32	32	32		<input type="checkbox"/> (SPEAKER 2)
SG33	33	33	33	33	33	33	33	33	33	33	33	33	33	33		SPEAKER 2
SG34	34	34	34	34	34	34	34	34	34	34	34	34	34	34		<input type="checkbox"/> (VMAx)
SG35	35	35	35	35	35	35	35	35	35	35	35	35	35	35		VMAx

*. Refer to Circuit of external Current Amplifying Example.

MODEL : HCA-16ML08
 ANODE CONNECTION
 Rev. (1) 26-Jun-2003

HVIST72F321R (U-COM) : IC81

Figure 1. Device Block Diagram

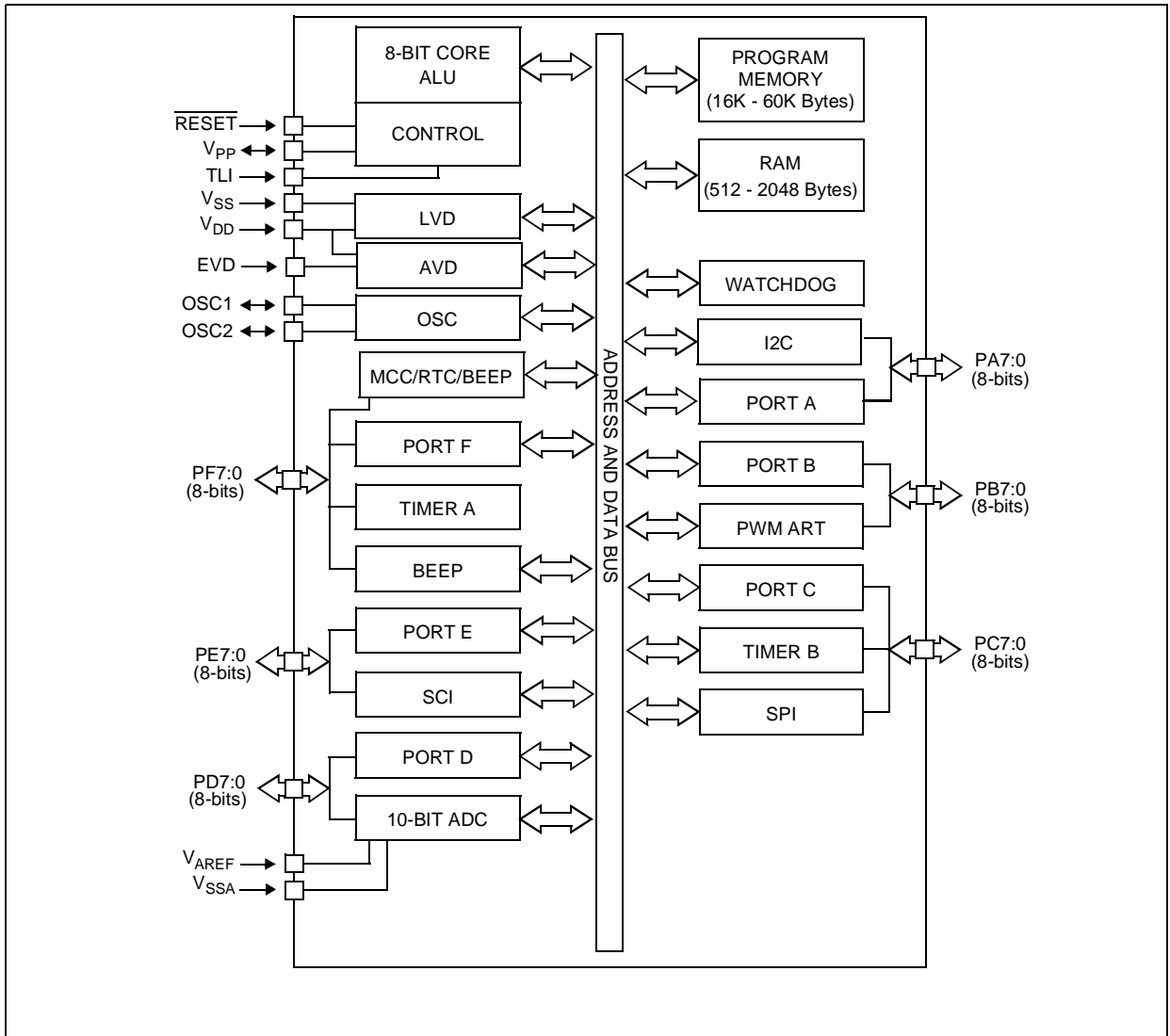

2 PIN DESCRIPTION

Figure 2. 64-Pin TQFP 14x14 and 10x10 Package Pinout

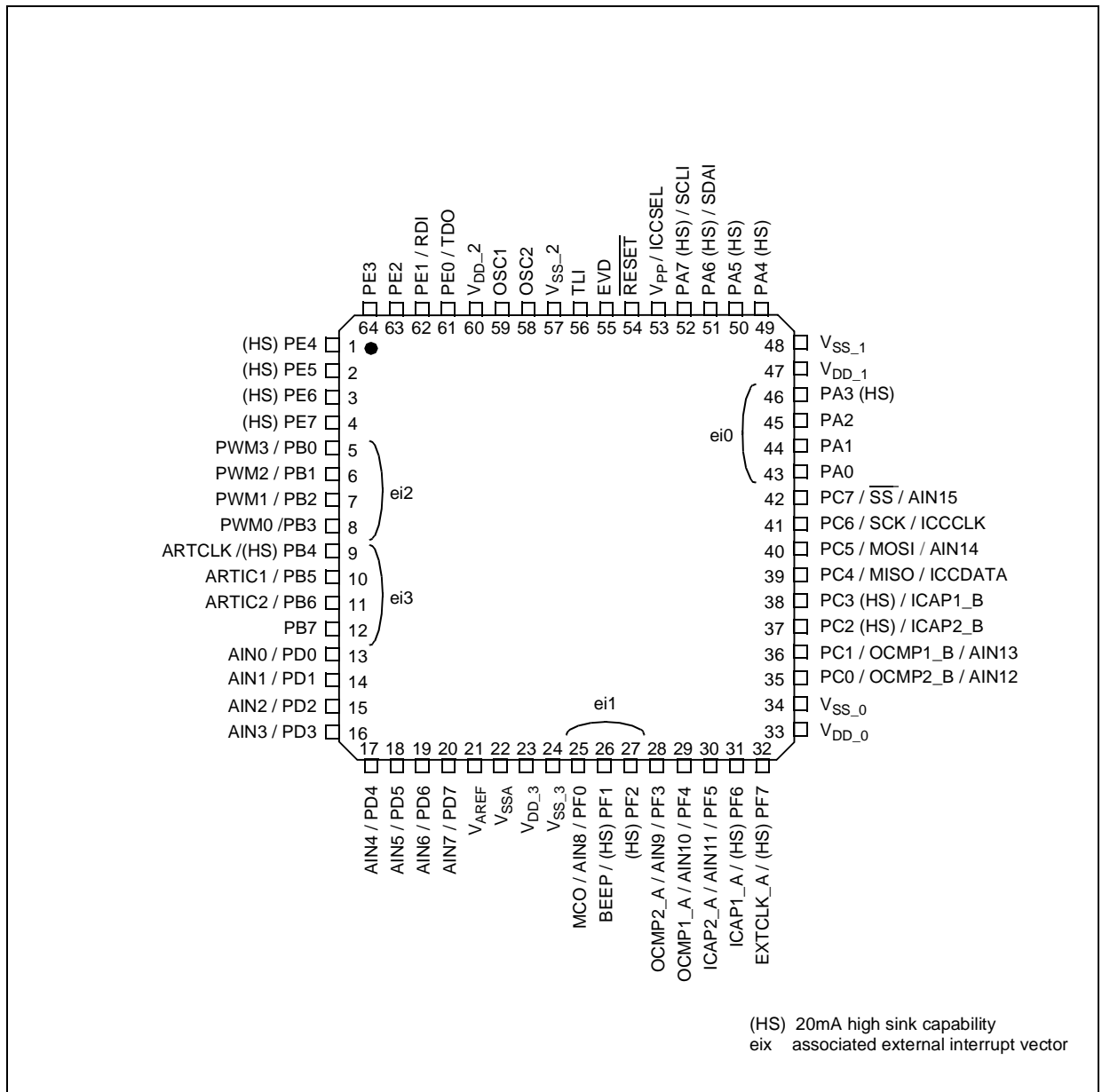

PIN DESCRIPTION (Cont'd)

For external pin connection guidelines, refer to See “ELECTRICAL CHARACTERISTICS” on page 135.

Legend / Abbreviations for Table 1:

Type: I = input, O = output, S = supply

Input level: A = Dedicated analog input

In/Output level: C = CMOS 0.3V_{DD}/0.7V_{DD}
 C_T= CMOS 0.3V_{DD}/0.7V_{DD} with input trigger
 T_T= TTL 0.8V / 2V with Schmitt trigger

Output level: HS = 20mA high sink (on N-buffer only)

Port and control configuration:

- Input: float = floating, wpu = weak pull-up, int = interrupt ¹⁾, ana = analog
- Output: OD = open drain ²⁾, PP = push-pull

Refer to “I/O PORTS” on page 45 for more details on the software configuration of the I/O ports.

The RESET configuration of each pin is shown in bold. This configuration is valid as long as the device is in reset state.

Table 1. Device Pin Description

Pin n°	Pin Name	Type	Level		Port						Main function (after reset)	Alternate function
			Input	Output	Input				Output			
					float	wpu	int	ana	OD	PP		
1	PE4 (HS)	I/O	C _T	HS	X	X			X	X	Port E4	
2	PE5 (HS)	I/O	C _T	HS	X	X			X	X	Port E5	
3	PE6 (HS)	I/O	C _T	HS	X	X			X	X	Port E6	
4	PE7 (HS)	I/O	C _T	HS	X	X			X	X	Port E7	
5	PB0/PWM3	I/O	C _T		X		ei2		X	X	Port B0	PWM Output 3
6	PB1/PWM2	I/O	C _T		X		ei2		X	X	Port B1	PWM Output 2
7	PB2/PWM1	I/O	C _T		X		ei2		X	X	Port B2	PWM Output 1
8	PB3/PWM0	I/O	C _T		X		ei2		X	X	Port B3	PWM Output 0
9	PB4 (HS)/ARTCLK	I/O	C _T	HS	X		ei3		X	X	Port B4	PWM-ART External Clock
10	PB5 / ARTIC1	I/O	C _T		X		ei3		X	X	Port B5	PWM-ART Input Capture 1
11	PB6 / ARTIC2	I/O	C _T		X		ei3		X	X	Port B6	PWM-ART Input Capture 2
12	PB7	I/O	C _T		X		ei3		X	X	Port B7	
13	PD0/AIN0	I/O	C _T		X	X		X	X	X	Port D0	ADC Analog Input 0
14	PD1/AIN1	I/O	C _T		X	X		X	X	X	Port D1	ADC Analog Input 1
15	PD2/AIN2	I/O	C _T		X	X		X	X	X	Port D2	ADC Analog Input 2
16	PD3/AIN3	I/O	C _T		X	X		X	X	X	Port D3	ADC Analog Input 3
17	PD4/AIN4	I/O	C _T		X	X		X	X	X	Port D4	ADC Analog Input 4
18	PD5/AIN5	I/O	C _T		X	X		X	X	X	Port D5	ADC Analog Input 5
19	PD6/AIN6	I/O	C _T		X	X		X	X	X	Port D6	ADC Analog Input 6
20	PD7/AIN7	I/O	C _T		X	X		X	X	X	Port D7	ADC Analog Input 7
21	V _{AREF}	I										Analog Reference Voltage for ADC
22	V _{SSA}	S										Analog Ground Voltage
23	V _{DD_3}	S										Digital Main Supply Voltage

Pin n°	Pin Name	Type	Level		Port						Main function (after reset)	Alternate function	
			Input	Output	Input				Output				
					float	wpu	int	ana	OD	PP			
24	V _{SS_3}	S										Digital Ground Voltage	
25	PF0/MCO/AIN8	I/O	C _T		X	ei1	X	X	X	Port F0	Main clock out (f _{osc} /2)	ADC Analog Input 8	
26	PF1 (HS)/BEEP	I/O	C _T	HS	X	ei1		X	X	Port F1	Beep signal output		
27	PF2 (HS)	I/O	C _T	HS	X		ei1		X	X	Port F2		
28	PF3/OCMP2_A/AIN9	I/O	C _T		X	X		X	X	Port F3	Timer A Output Compare 2	ADC Analog Input 9	
29	PF4/OCMP1_A/AIN10	I/O	C _T		X	X		X	X	Port F4	Timer A Output Compare 1	ADC Analog Input 10	
30	PF5/ICAP2_A/AIN11	I/O	C _T		X	X		X	X	Port F5	Timer A Input Capture 2	ADC Analog Input 11	
31	PF6 (HS)/ICAP1_A	I/O	C _T	HS	X	X		X	X	Port F6	Timer A Input Capture 1		
32	PF7 (HS)/EXTCLK_A	I/O	C _T	HS	X	X		X	X	Port F7	Timer A External Clock Source		
33	V _{DD_0}	S									Digital Main Supply Voltage		
34	V _{SS_0}	S									Digital Ground Voltage		
35	PC0/OCMP2_B/AIN12	I/O	C _T		X	X		X	X	Port C0	Timer B Output Compare 2	ADC Analog Input 12	
36	PC1/OCMP1_B/AIN13	I/O	C _T		X	X		X	X	Port C1	Timer B Output Compare 1	ADC Analog Input 13	
37	PC2 (HS)/ICAP2_B	I/O	C _T	HS	X	X		X	X	Port C2	Timer B Input Capture 2		
38	PC3 (HS)/ICAP1_B	I/O	C _T	HS	X	X		X	X	Port C3	Timer B Input Capture 1		
39	PC4/MISO/ICCDATA	I/O	C _T		X	X		X	X	Port C4	SPI Master In / Slave Out Data	ICC Data Input	
40	PC5/MOSI/AIN14	I/O	C _T		X	X		X	X	Port C5	SPI Master Out / Slave In Data	ADC Analog Input 14	
41	PC6/SCK/ICCCLK	I/O	C _T		X	X		X	X	Port C6	SPI Serial Clock	ICC Clock Output	
42	PC7/ \overline{SS} /AIN15	I/O	C _T		X	X		X	X	Port C7	SPI Slave Select (active low)	ADC Analog Input 15	
43	PA0	I/O	C _T		X	ei0		X	X	Port A0			
44	PA1	I/O	C _T		X	ei0		X	X	Port A1			
45	PA2	I/O	C _T		X	ei0		X	X	Port A2			
46	PA3 (HS)	I/O	C _T	HS	X		ei0	X	X	Port A3			
47	V _{DD_1}	S								Digital Main Supply Voltage			
48	V _{SS_1}	S								Digital Ground Voltage			
49	PA4 (HS)	I/O	C _T	HS	X	X		X	X	Port A4			
50	PA5 (HS)	I/O	C _T	HS	X	X		X	X	Port A5			
51	PA6 (HS)/SDAI	I/O	C _T	HS	X			T		Port A6	I ² C Data ¹⁾		
52	PA7 (HS)/SCLI	I/O	C _T	HS	X			T		Port A7	I ² C Clock ¹⁾		

Pin n°	Pin Name	Type	Level		Port						Main function (after reset)	Alternate function	
			Input	Output	Input				Output				
					float	wpu	int	ana	OD	PP			
53	V _{PP} / ICCSEL	I										Must be tied low. In flash programming mode, this pin acts as the programming voltage input V _{PP} . See Section 12.9.2 for more details. High voltage must not be applied to ROM devices	
54	RESET	I/O	C _T									Top priority non maskable interrupt.	
55	EVD											External voltage detector	
56	TLI	I	C _T				X					Top level interrupt input pin	
57	V _{SS_2}	S										Digital Ground Voltage	
58	OSC2 ³⁾	I/O										Resonator oscillator inverter output or capacitor input for RC oscillator	
59	OSC1 ³⁾	I										External clock input or Resonator oscillator inverter input or resistor input for RC oscillator	
60	V _{DD_2}	S										Digital Main Supply Voltage	
61	PE0/TDO	I/O	C _T		X	X			X	X	Port E0	SCI Transmit Data Out	
62	PE1/RDI	I/O	C _T		X	X			X	X	Port E1	SCI Receive Data In	
63	PE2	I/O	C _T			X					Port E2		
64	PE3	I/O	C _T		X	X			X	X	Port E3		

AT24C08N10SC (EEPROM) : IC83

BLOCK DIAGRAM

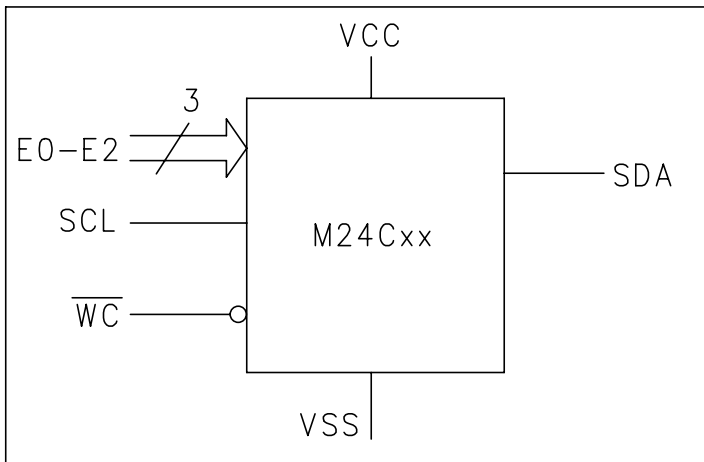

SIGNAL NAMES

E0,E1,E2	Chip Enable
SDA	Serial Data
SCL	Serial Clock
\overline{WC}	Write Control
Vcc	Supply Voltage
Vss	Ground

DIP, SO and TSSOP Connections

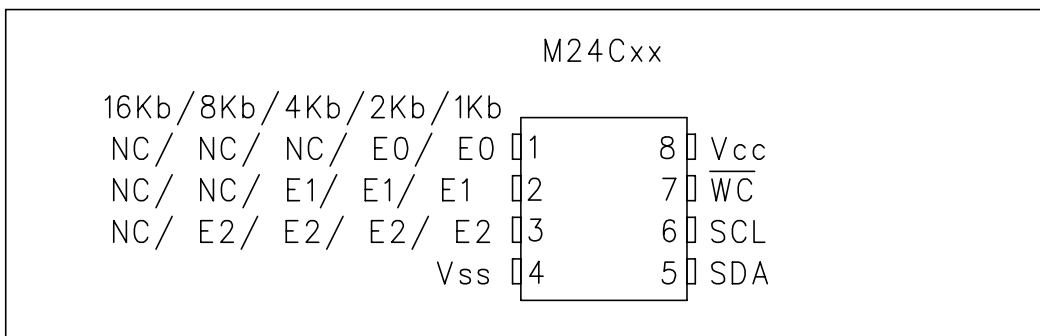



NJM2068

LOW-NOISE DUAL OPERATIONAL AMPLIFIER

■ GENERAL DESCRIPTION

The NJM2068 is a high performance, low noise dual operational amplifier. This amplifier features popular pin-out, superior noise performance, and superior total harmonic distortion. This amplifier also features guaranteed noise performance with substantially higher gain-bandwidth product and slew rate which far exceeds that of the 4558 type amplifier. The specially designed low noise input transistors allow the NJM2068 to be used in very low noise signal processing applications such as audio preamplifiers and servo error amplifier.

■ FEATURES

- Operating Voltage (±4V ~ ±18V)
- Low Total Harmonic Distortion (0.001% typ.)
- Low Noise Voltage (FLAT+JISA, 0.56 μV typ.)
- High Slew Rate (6V/μs typ.)
- Unity Gain Bandwidth (27MHz @f=10kHz)
- Package Outline DIP8, DMP8, SIP8, SSOP8
- Bipolar Technology

■ PACKAGE OUTLINE

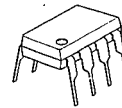

NJM2068D



NJM2068M



NJM2068V

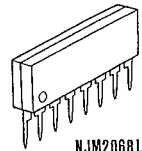

NJM2068L

■ PIN CONFIGURATION

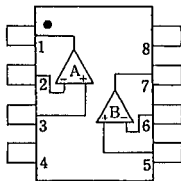

NJM2068D
NJM2068M
NJM2068V

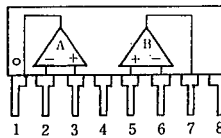

NJM2068L

- PIN FUNCTION
1. A OUTPUT
 2. A-INPUT
 3. A+INPUT
 4. V-
 5. B+INPUT
 6. B-INPUT
 7. B OUTPUT
 8. V+

■ EQUIVALENT CIRCUIT (1/2 Shown)

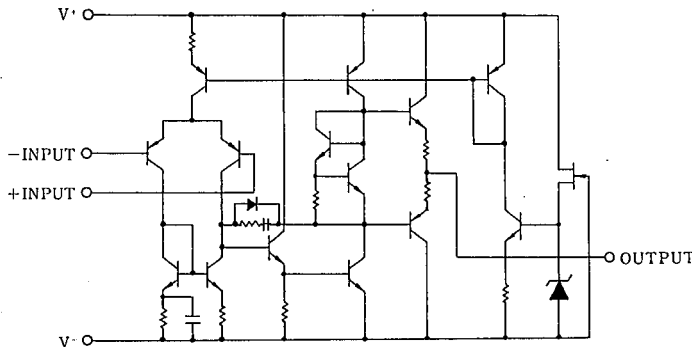

■ BLOCK DIAGAM (NJM2296M) : IC91

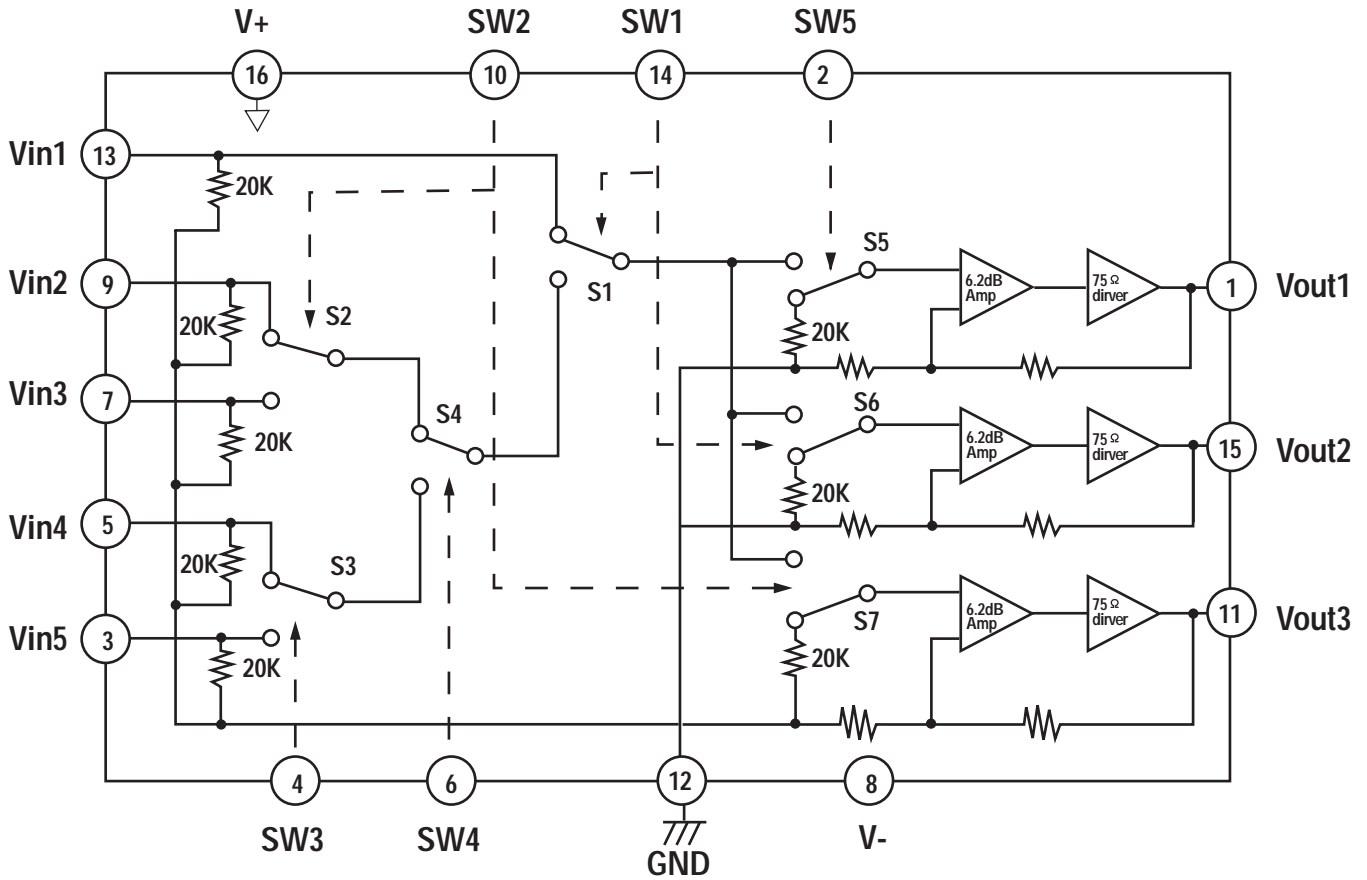

*** Normally mute**
Above circuits show that the switches are set at low.

KP1010B : IC92

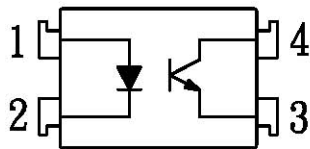

- 1. Anode
- 2. Cathode
- 3. Emitter
- 4. Collector

RE5VL28CATZ (VOLTAGE DETECTOR : IC85)

■ BLOCK DIAGRAM

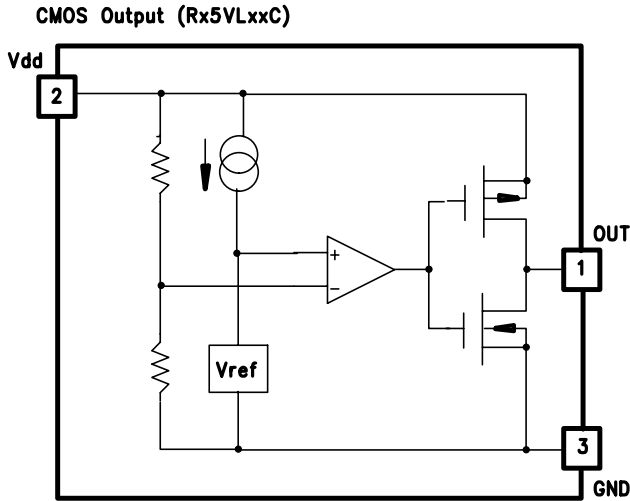

■ TIME CHART

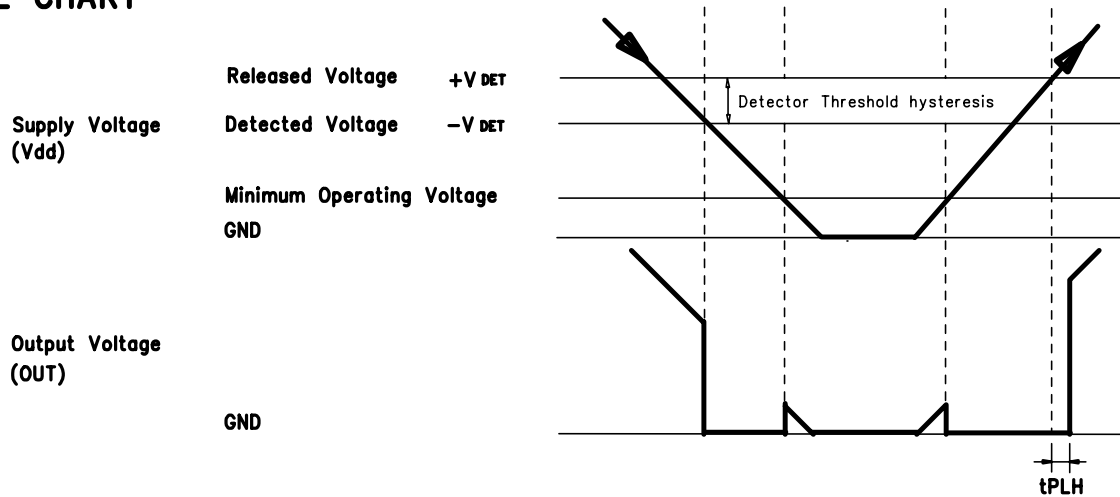

■ DEFINITION OF OUTPUT DELAY TIME tPLH

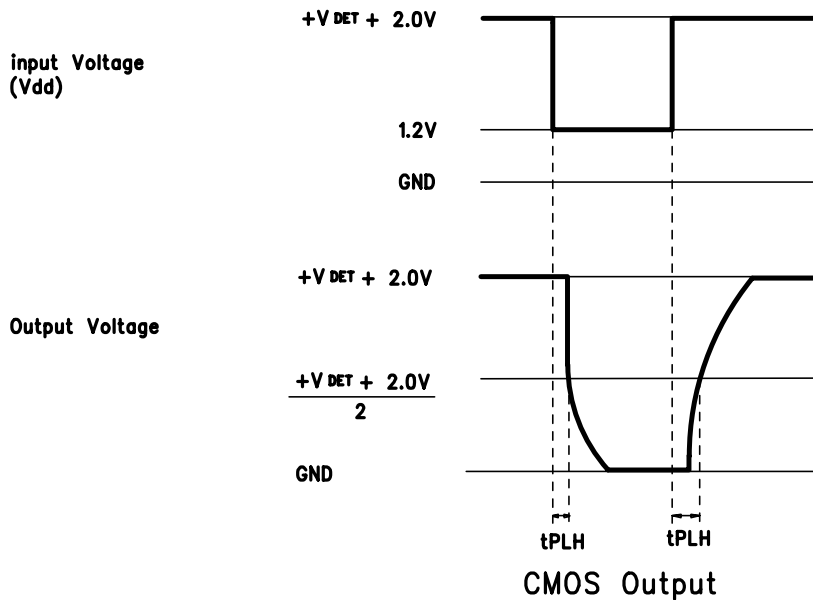

S-80145ALMC (RESET I.C) : IC84

PIN CONFIGURATION

*SOT-23-5

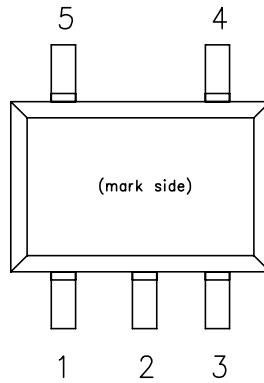

PIN DESCRIPTION

Pin No.	Symbol	Description
1	OUT	Output Pin
2	V _{DD}	Input and power source for device itself
3	GND	Ground Pin
4	NC	No Connection
5	C _D	Pin for external capacitor

BLOCK DIAGRAMS

*Nch Open Drain Output(RN5VDxxA)

*CMOS Output (RN5VDxxC)

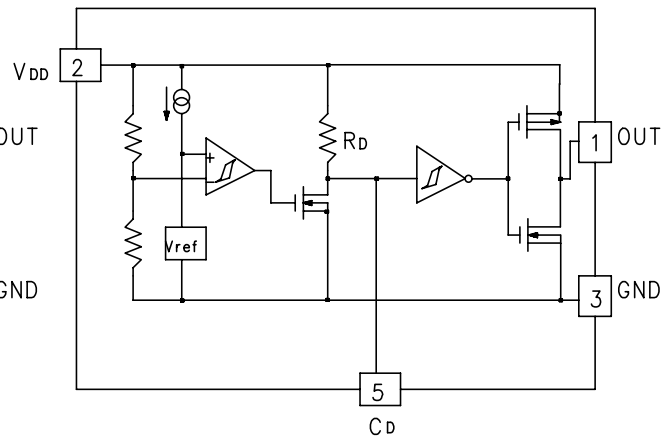
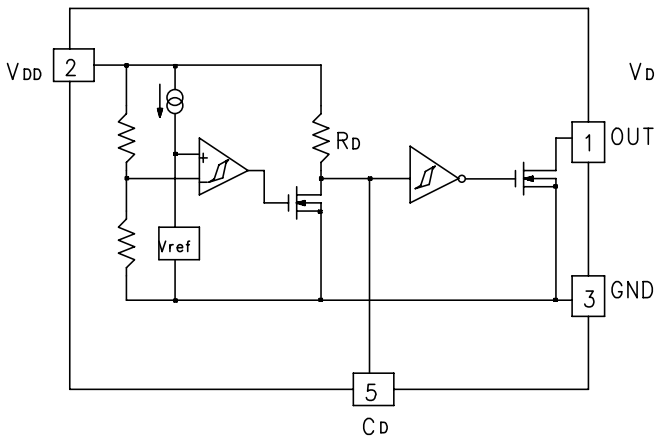

TC9164AF (FUNCTION/INPUT) : IC12

■ BLOCK DIAGRAM

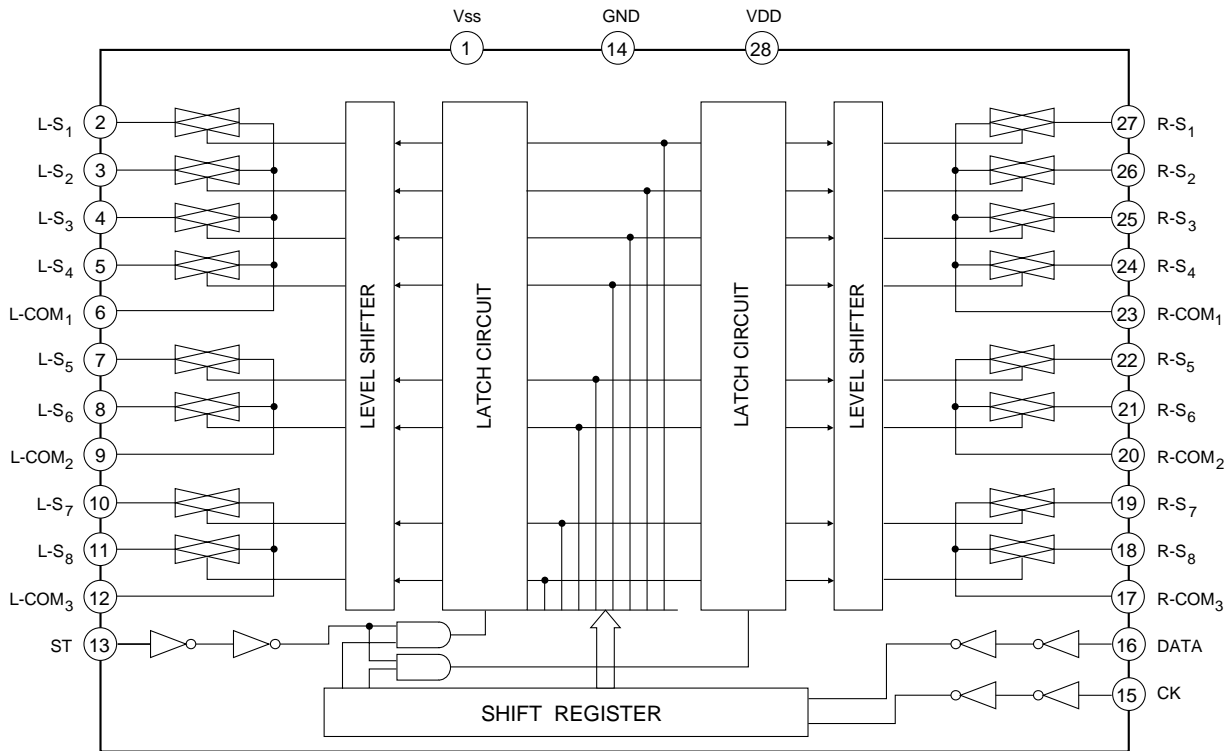

TC9163AF (FUNCTION/INPUT) : IC13

■ BLOCK DIAGRAM

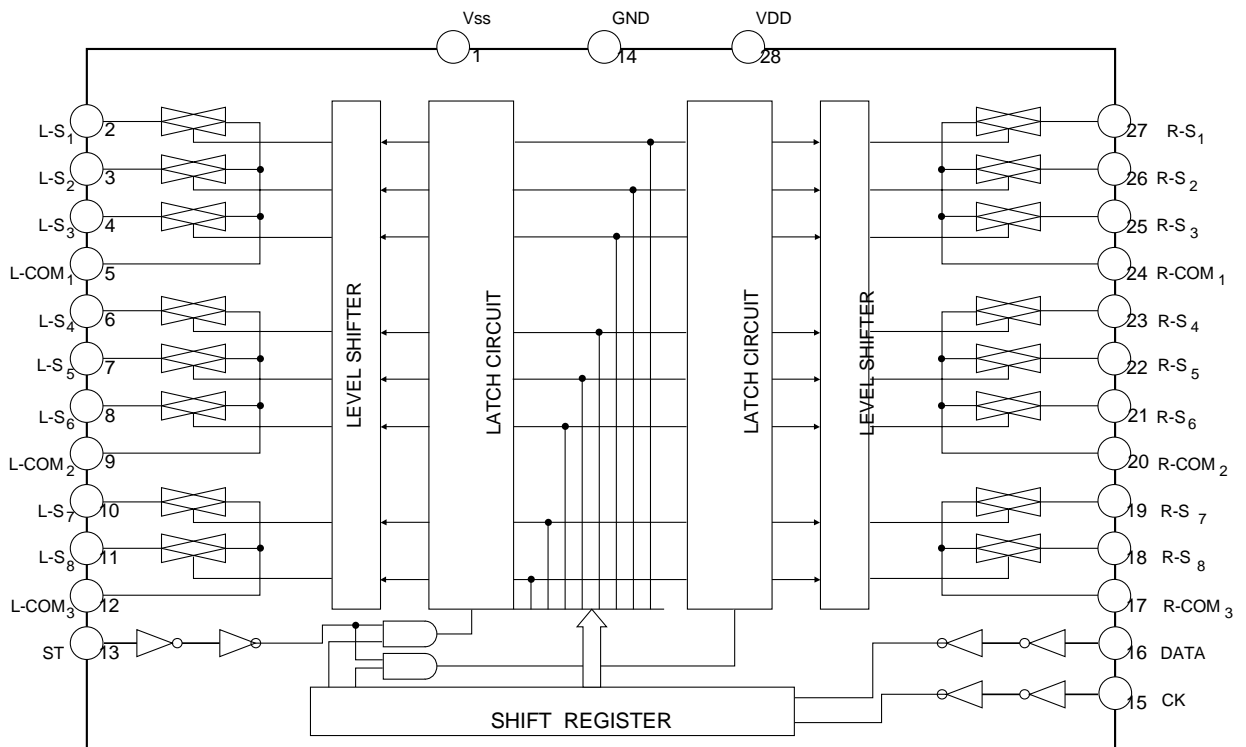

ELECTRONIC VOLUME CONTROL IC (IC15)

BLOCK DIAGRAM (TC9459F)

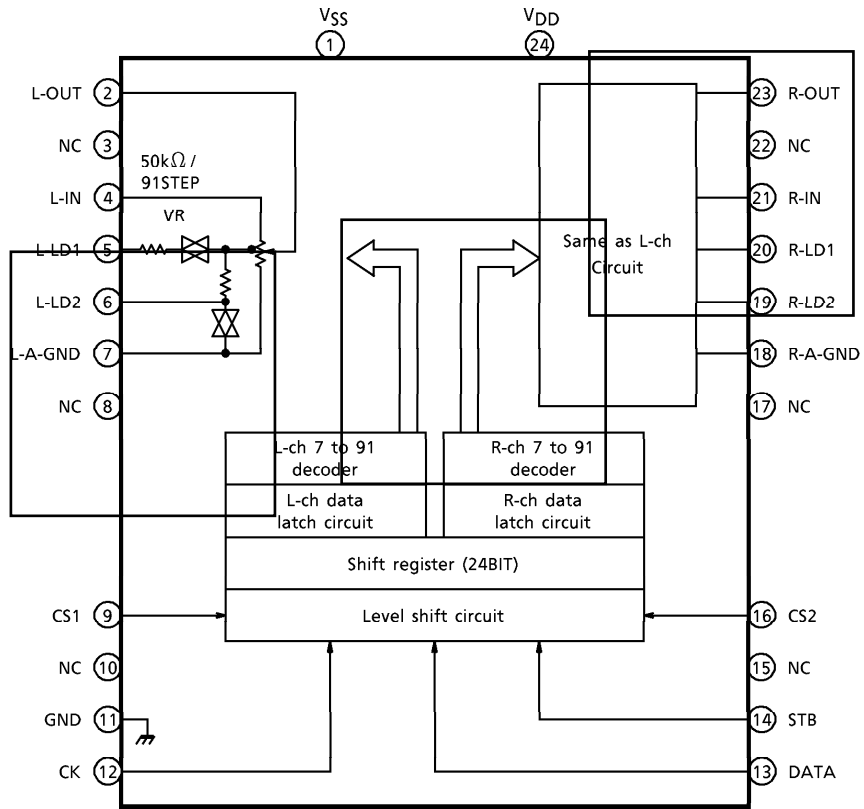



PIN DESCRIPTION

Numeral in () means the pin No. of TC9459F.

PIN No.	SYMBOL	PIN NAME	FUNCTION	REMARK										
1 (1)	V _{SS}	Negative power supply pin	When using dual power supplies <ul style="list-style-type: none"> V_{DD} = 6.0~17V GND = 0V V_{SS} = -6.0~-17V When using a single power supply <ul style="list-style-type: none"> V_{DD} = 6.0~18V GND = V_{SS} = 0V 	—										
28 (24)	V _{DD}	Positive power supply pin												
13 (11)	GND	Digital GND pin												
3 (2)	L-OUT	Volume output pin	• Volume circuit	—										
26 (23)	R-OUT													
5 (4)	L-IN	Volume input pin												
24 (21)	R-IN													
6 (5)	L-LD1	Loudness tap output pin			<table border="1" style="margin-left: auto; margin-right: auto;"> <tr> <td style="width: 50%;"></td> <td style="width: 25%;">LA1</td> <td style="width: 25%;">LA2</td> </tr> <tr> <td>LOUDNESS "ON"</td> <td>ON</td> <td>OFF</td> </tr> <tr> <td>LOUDNESS "OFF"</td> <td>OFF</td> <td>ON</td> </tr> </table>		LA1	LA2	LOUDNESS "ON"	ON	OFF	LOUDNESS "OFF"	OFF	ON
	LA1					LA2								
LOUDNESS "ON"	ON					OFF								
LOUDNESS "OFF"	OFF					ON								
23 (20)	R-LD1													
7 (6)	L-LD2													
22 (19)	R-LD2													
8 (7)	L-A-GND	Analog GND pin												
21 (18)	R-A-GND													
10 (9)	CS1	Chip select input pin	Up to 4 chips on the same bus can be used by switching over chip select code.	—										
19 (16)	CS2													
14 (12)	CK	Clock input pin	Data transfer clock input	Low threshold value input pin										
15 (13)	DATA	Data input pin	Volume setup serial data input											
16 (14)	STB	Strobe input pin	Data write strobe input											
2 (3)	NC	No connection	—	—										
27 (22)														
4														
25														
9 (8)														
20 (17)														
11														
18														
12 (10)														
17 (15)														

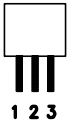
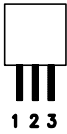
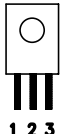
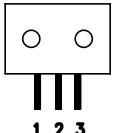
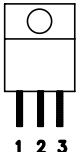
TRANSISTOR , REGULATOR IC BLOCK DIAGRAM

<p>T0-92M</p>  <p>1. Emitter 2. Collector 3. Base</p> <p>1 2 3</p> <p>KRA107M KRC107M KSA1175Y KSC2785Y KTC2874B</p>	<p>T0-92</p>  <p>1. Emitter 2. Collector 3. Base</p> <p>1 2 3</p> <p>KTA1271Y KSC945CY KTA1268GR KTC3200GR</p>	<p>T0-126</p>  <p>1. Emitter 2. Collector 3. Base</p> <p>1 2 3</p> <p>KTA1360Y KTC3423Y KTC3114A</p>
<p>T0-3P</p>  <p>1. Base 2. Collector 3. Emitter</p> <p>1 2 3</p> <p>2SB1570 2SD2401</p>	<p>T0-220</p>  <p>1. INPUT 2. GND 3. OUTPUT</p> <p>1 2 3</p> <p>L7805CP L7815CP</p>	<p>T0-220</p>  <p>1. GND 2. INPUT 3. OUTPUT</p> <p>1 2 3</p> <p>L7905CP L7915CP</p>

HK3480 ELECTRICAL PARTS LIST

Ref. Designator	Part Number	Description	
PCB, FRONT			
<i>Capacitors</i>			
C835	CCEA0JH102T	CAP , ELECT	1000UF 6.3V
C803,812	CCEA1AH471T	CAP , ELECT	470UF 10V
C810	CCEA1AKS101T	CAP. ELECT	100UF 10V
C909,910,921,922	CCEA1CH101T	CAP , ELECT	100UF 16V
C820	CCEA1CH331T	CAP , ELECT	330UF 16V
C707,708	CCEA1CKS470T	CAP , ELECT	47UF/16V
C821	CCEA1CKS4R7T	CAP. ELECT	4.7UF 16V
C913	CCEA1EH220T	CAP , ELECT	22UF/25V
C701,702,711~714,802,817	CCEA1HKS100T	CAP , ELECT	UF10 50V KS
C904~908	CCKT1H101KB	CAP , CERAMIC	100PF 50V KB
C801	CCKT1H104ZF	CAP , CERAMIC	50V 0.1UF
C703,704,726	HCBS1H101KBT	CAP , CERAMIC	100PF 50V K
C832,833	HCBS1H102KBT	CAP , CERAMIC	1000PF 50V B
C745	HCBS1H103ZFT	CAP , CERAMIC	0.01UF 50V Z
C727,744,808,809,819,838,839,914	HCBS1H104ZFT	CAP , CERAMIC	0.1UF 50V Z
C805,806	HCBS1H150JCT	CAP , CERAMIC	15PF 50V J
C822	HCBS1H151KBT	CAP , CERAMIC	150PF 50V K
C723,724	HCBS1H221KBT	CAP , CERAMIC	220PF 50V K
C728~730,804,811,815,816,818,830, 834,837,911,912	HCBS1H223ZFT	CAP , CERAMIC	0.022UF 50V Z
C709,710,813,814	HCBS1H470JT	CAP , CERAMIC	47PF 50V J
C807,823,824,840	HCBS1H821KBT	CAP , CERAMIC	820PF 50V K
C741,742	HCQ1H122JZT	CAP , MYLAR	1200PF 50V J
C603~606	HCQ1H473JZT	CAP , MYLAR	0.047UF 50V J
C715,716,719,720	KCFE1J183JBT	CAP , FILM	0.018UF 63V J
C721,722	KCFE1J332JBT	CAP , FILM	0.0033UF 63V J
C717,718	KCFE1J823JBT	CAP , FILM	0.082UF 63V J
<i>Resistors</i>			
R742,828,833,834,836,909,910	CRD20TJ100T	RES , CARBON	10 OHM 1/5W J
R705,706,829,830,870,918	CRD20TJ101T	RES , CARBON	100 OHM 1/5W J
R729,809,825~827,835,853,860, 863,908,911-913	CRD20TJ102T	RES , CARBON	1K OHM 1/5W J
R806~808,818,819,822,823, 837- 839,841,842,845,847-852,876	CRD20TJ103T	RES , CARBON	10K OHM 1/5W J
R701,702,707~710,723,724	CRD20TJ104T	RES , CARBON	100K OHM 1/5W J
R711	CRD20TJ105T	RES , CARBON	1M OHM 1/5W J
R712	CRD20TJ105T	RES , CARBON	1M OHM 1/5W J
R801	CRD20TJ122T	RES , CARBON	1.2K OHM 1/5W J
R854,861,864	CRD20TJ152T	RES , CARBON	1.5K OHM 1/5W J
R744	CRD20TJ181T	RES , CARBON	180 OHM 1/5W J
R855,862,865	CRD20TJ182T	RES , CARBON	1.8K OHM 1/5W J
R717,718,824	CRD20TJ222T	RES , CARBON	2.2K OHM 1/5W J
R713,714	CRD20TJ223T	RES , CARBON	22K OHM 1/5W J
R915	CRD20TJ271T	RES , CARBON	270 OHM 1/5W J
R727,728,820,856,866	CRD20TJ272T	RES , CARBON	2.7K OHM 1/5W J
R878	CRD20TJ273T	RES , CARBON	27K OHM 1/5W J
R733,734	CRD20TJ331T	RES , CARBON	330 OHM 1/5W J
R843,857,867,906,907,917	CRD20TJ332T	RES , CARBON	3.3K OHM 1/5W J

Ref. Designator	Part Number	Description	
R715,716,919	CRD20TJ392T	RES , CARBON	3.9K OHM 1/5W J
R916	CRD20TJ470T	RES , CARBON	47 OHM 1/5W J
R721,722,745	CRD20TJ471T	RES , CARBON	470 OHM 1/5W J
R831,832,844,846	CRD20TJ472T	RES , CARBON	4.7K OHM 1/5W J
R920	CRD20TJ473T	RES , CARBON	47K OHM 1/5W J
R726	CRD20TJ560T	RES , CARBON	56 OHM 1/5W J
R858,868	CRD20TJ562T	RES , CARBON	5.6K OHM 1/5W J
R719,720	CRD20TJ681T	RES , CARBON	680 OHM 1/5W J
R725,901~905	CRD20TJ750T	RES , CARBON	75 OHM 1/5W J
R859,869	CRD20TJ752T	RES , CARBON	7.5K OHM 1/5W J
R875	CRD20TJ820T	RES , CARBON	82 OHM 1/5W J
R921,922	CRG2ANJ470H	RES , METAL OXIDE FILM	47 OHM 2W J
VR71,72	CVV2X07C104Z	RES , VARIABLE(TONE)	RK14128030214C
VR73	CVV2X05M104Z	RES , VARIABLE(BALANCE)	RK14128030214Y
VR81	HSR2A029Z	VR , ENCODER	

Semiconductors

IC83	HVIAT24C08N10SC	I.C	AT24C08N10SC2.7
IC87	HVIL7805CP	I.C, REGULATOR	L7805CP
IC88	HVIL7905CP	I.C, REGULATOR	L7905CP
IC71	HVINJM2068MDTE1	I.C , OP AMP	NJM2068MD-TE1
IC91	HVINJM2296M	I.C , VIDEO SW	NJM2296M
IC85	HVIRE5VL28CATZ	IC , RESET	RE5VL28CATZ
IC84	HVIS-80145ALMC	I.C RESET	S-80145ALMC
IC81	HVIST72F321R	IC , FLASH U-COM	ST72F321R9
IC92	BVIKP1010B	IC, PHOTO COUPLER	KP1010B
D706	CVD50BOGDWGA	L.E.D , 2 COLOR	
D701~705	CVD52CSBBCEAB2	BLUE L.E.D	
D707,708,801~808,901-903	HVD1SS133MT	DIODE	1SS133T-77
Q802,806,814,901	HVTKRA107MT	T.R	KRA107M
Q801,803,805,806,808,813	HVTKRC107MT	T.R	KRC107M
Q811,812	HVTKSC945CYT	T.R	KSC945CY
Q804	HVTKTA1271YT	T.R	KTA1271Y
Q809	KVTKSA1175YT	T.R	KSA1175Y
Q810	KVTKSC2785YT	T.R	KSC2785Y

Miscellaneous

L801	HLQ02C100KT	COIL , AXAIL	
S701,801~819	HST1A020ZT	SW , TACT	
BN73	CWB2B903350EN	WIRE ASS'Y	
BN83,84	CWB2B904070EN	WIRE ASS'Y	
BN89	CWB2B907160EN	WIRE ASS'Y	
BN82	CWB2B907350EN	WIRE ASS'Y	
BN91	CWB2B909200EN	WIRE ASS'Y	
JW72	CWE8202110RV	WIRE, ASS'Y	
JW73	CWZAVR2550JW82	WIRE , ASS'Y	
BN71	CWZHK3380BN71	WIRE ASS'Y	
BN72	CWZHK3380BN72	WIRE ASS'Y	
BN81	CWZHK3380BN81	WIRE ASS'Y	
CN62	KJP02GA89ZM	WAFER	MOLEX35328-02
CN63	KJP03GA90ZM	WAFER	MOLEX35313-0310
CN83,84	KJP04GA19ZM	WAFER	MOLEX53014-0410
CN64	KJP06GA01ZM	WAFER	MOLEX 5267-06A

Ref. Designator	Part Number	Description	
CN89	KJP07GA19ZM	WAFER	MOLEX53014-0710
CN90	KJP07HA37ZM	WAFER	
CN81	CJP20GB163ZW	WAFER	
JK93	CJJ2D008Z	JACK , STEREO	
JK94	CJJ2D008Z	JACK , STEREO	
JK71	CJJ2E026Z	JACK , HEADPHONE(SILVER)	
JK91	CJJ4N043Z	JACK , BOARD	
JK92	CJJ4S010Z	JACK , BOARD	
JK72	CJJ4S023Y	JACK , BOARD	
FIP1	HFLHCA16ML08-1	F.I.P	HCA16ML08-1
X801	HOX04000E150C	CRYSTAL , 4MHZ	
RC81	HRVKSM603TH2	REMOCON SENSER	CN KSM-603TH2

PCB , MAIN

Capacitors

C626	CCEA1AH101T	CAP. ELECT	100UF 10V
C343	CCEA1AH471T	CAP , ELECT	470UF 10V
C107,108,111,112,121-124,175, 176,181,182,195,196,219,220,305, 306,613,614,622	CCEA1CH101T	CAP , ELECT	100UF 16V
C625	CCEA1EH102E	CAP , ELECT	1000UF 25V
C612	CCEA1EH222E	CAP. ELECT.	2200UF 25V
C401,402,405,406	CCEA1EH470T	CAP , ELECT	47UF 25V
C318	CCEA1HH100T	CAP. ELECT	10UF 50V
C315~317	CCEA1HH100TS	CAP , ELECT	10UF/50V 105°C
C240	CCEA1HH1R0T	CAP , ELECT	1UF 50V
C619,629	CCEA1HH470T	CAP , ELECT	47UF 50V
C211,212,215,216,341,403,404, 407,408,620	CCEA1HH4R7T	CAP , ELECT	4.7UF 50V
C632	CCEA1JH101E	CAP , ELECT	100UF 63V
C103,104,117,118,191-194,301,302	CCEA1VH100T	CAP , ELECT	10UF 35V
C601,602	CCET63VKL5153NK	CAP , ELECT	15000UF 63V
C101,102,105,106	CCKT1H101KB	CAP , CERAMIC	100PF 50V KB
C197,198,342,615,616,623,624,627	CCKT1H223ZF	CAP , CERAMIC	0.022UF 50V ZF
C183~185,303,304	CCKT1H471KB	CAP , CERAMIC	470PF 50V KB
C201~204	HCBS1H101KBT	CAP , CERAMIC	100PF 50V K
C628,630	HCBS1H103ZFT	CAP , CERAMIC	0.01UF 50V Z
C145,146	HCBS1H104ZFT	CAP , CERAMIC	0.1UF 50V Z
C311,312	HCBS1H120JCT	CAP , CERAMIC	12PF 50V J
C131~144	HCBS1H221KBT	CAP , CERAMIC	220PF 50V K
C313,314	HCBS1H330JT	CAP , CERAMIC	33PF 50V J
C125~130	HCBS1H471KBT	CAP , CERAMIC	470PF 50V K
C351,352	HCBS1H681KBT	CAP , CERAMIC	680PF 50V K
C611	HCEA1EH332E	CAP , ELECT	3300UF 25V
C307~310	HCEA1JH471E	CAP , ELECT	470UF 63V
C109,110,213,214,222	HCQ11H102JZT	CAP , MYLAR	1000PF 50V J
C115,116	HCQ11H152JZT	CAP , MYLAR	1500PF 50V J
C119,120	HCQ11H183JZT	CAP , MYLAR	0.018UF 50V J
C319,320,607~609	HCQ11H473JZT	CAP , MYLAR	0.047UF 50V J
C113,114,331~336	HCQ11H562JZT	CAP , MYLAR	5600PF 50V J
C409	KCFE1J334JBT	CAP , FILM	0.33UF 63V J
C621	KCKDKS472ME	CAP , CERAMIC(X1/Y2/SC)	0.0047UF/2.5KV

Ref. Designator	Part Number	Description	
<i>Resistors</i>			
R307,308	CRD20TJ100T	RES , CARBON	10 OHM 1/5W J
R107,108,121,123,124,171,172,181, 182,195,196,201-204,219,220	CRD20TJ101T	RES , CARBON	100 OHM 1/5W J
R101,102,359,360,363,363,386,401, 402,407,408,420,445,446	CRD20TJ102T	RES , CARBON	1K OHM 1/5W J
R240,365,366,415-419,424	CRD20TJ103T	RES , CARBON	10K OHM 1/5W J
R103-106,117,118,213,214,221, 222,405,406,411,412,443,444,618	CRD20TJ104T	RES , CARBON	100K OHM 1/5W J
R255	CRD20TJ105T	RES , CARBON	1M OHM 1/5W J
R321,322,343,344,611	CRD20TJ122T	RES , CARBON	1.2K OHM 1/5W J
R607,608	CRD20TJ123T	RES , CARBON	12K OHM 1/5W J
R427	CRD20TJ151T	RES , CARBON	150 OHM 1/5W J
R223,224,315-318,384	CRD20TJ152T	RES , CARBON	1.5K OHM 1/5W J
R361,362,609,610,619,620	CRD20TJ182T	RES , CARBON	1.8K OHM 1/5W J
R191-194,205-208	CRD20TJ184T	RES , CARBON	180K OHM 1/5W J
R215,216,425	CRD20TJ202T	RES , CARBON	2K OHM 1/5W J
R413,414	CRD20TJ220T	RES , CARBON	22 OHM 1/5W J
R311-314,403,404	CRD20TJ221T	RES , CARBON	220 OHM 1/5W J
R217, 218,617	CRD20TJ222T	RES , CARBON	2.2K OHM 1/5W J
R339-342	CRD20TJ223T	RES , CARBON	22K OHM 1/5W J
R309,310,357,358,428,431,432,436, 438,441,442	CRD20TJ271T	RES , CARBON	270 OHM 1/5W J
R381,382	CRD20TJ273T	RES , CARBON	27K OHM 1/5W J
R345,346	CRD20TJ331T	RES , CARBON	330 OHM 1/5W J
R235-239,303,304,319,320	CRD20TJ332T	RES , CARBON	3.3K OHM 1/5W J
R409,410	CRD20TJ392T	RES , CARBON	3.9K OHM 1/5W J
R383	CRD20TJ433T	RES , CARBON	43K OHM 1/5W J
R391-393	CRD20TJ470T	RES , CARBON	47 OHM 1/5W J
R115,116,125-144,183-185,211, 305,306	CRD20TJ471T	RES , CARBON	470 OHM 1/5W J
R111,112,173,174,367,368,385	CRD20TJ473T	RES , CARBON	47K OHM 1/5W J
R151-164	CRD20TJ474T	RES , CARBON	470K OHM 1/5W J
R434	CRD20TJ4R7T	RES , CARBON	4.7 OHM 1/5W J
R426,429,430,435,437,439,440	CRD20TJ512T	RES , CARBON	5.1K OHM J
R612,613	CRD20TJ560T	RES , CARBON	56 OHM 1/5W J
R323-334	CRD20TJ561T	RES , CARBON	560 OHM 1/5W J
R234	CRD20TJ562T	RES , CARBON	5.6K OHM 1/5W J
R109,110	CRD20TJ564T	RES , CARBON	560K OHM 1/5W J
R421,423	CRD20TJ622T	RES , CARBON	6.2K OHM 1/5W J
R335-338	CRD20TJ750T	RES , CARBON	75 OHM 1/5W J
R113,114	CRD20TJ751T	RES , CARBON	750 OHM 1/5W J
R433,614	CRD20TJ820T	RES , CARBON	82 OHM 1/5W J
R241	CRD20TJ822T	RES , CARBON	8.2K OHM 1/5W J
R122	CRD25TJ101T	RES , CARBON	100 OHM 1/4W J
R601-604	CRD25TJ393T	RES , CARBON	39K OHM 1/4W J
R371-374	CRD25TJ470T	RES , CARBON	47 OHM 1/4W J
R212	CRD25TJ471T	RES , CARBON	470 OHM 1/4W J
R355,356	CRF5EKR22HX2	RES , CEMENT	0.22OHM(*2), 5W
R375,376	CRG1ANJ100H	RES , METAL OXIDE FILM	10 OHM 1W J
R377,378	CRG1ANJ221H	RES , METAL OXIDE FILM	220 OHM 1W J
R631	BRDERC12UGK335T	RES , CARBON JP	3.3M OHM 1/2W
R351-354	KRD25FJ180T	RES , CARBON	18 OHM 1/4W J
R347-350	KRD25FJ3R3T	RES , CARBON	3.3 OHM 1/4W J
R615	KRQ1AJ100H	RES , FUSE	10 OHM 1W J

Ref. Designator	Part Number	Description	
R605,606,616	KRQ1AJR47H	RES , FUSE	0.47 OHM 1W J
VR31,32	HVN1RA221B01T	RES , SEMI FIXED(220 OHM)	RH0615C100221
<i>Semiconductors</i>			
D601	HVDGBJ806MF	DIODE , BRIDGE	
D101~110,112~115,301-309,606, 612-614	HVD1SS133MT	DIODE	1SS133T-77
D602~605,607,615-618	KVD1N4003ST	DIODE	1N4003
D608,609	HVDMTZJ15BT	DIODE , ZENER	15V 1/2W
D611	HVDMTZJ6.2BT	DIODE , ZENER	6.2V 1/2W
Q209,332,337,338,602	HVTKRA107MT	T.R	KRA107M
Q210,335,336	HVTKRC107MT	T.R	KRC107M
Q307~310	HVTKTA1268GRT	T.R	KTA1268GR
Q603	HVTKTA1271YT	T.R	KTA1271Y
Q313,314	HVTKTA1360Y	T.R , PRE DRIVE	KTA1360Y
Q204~208	HVTKTC2874BT	T.R , MUTE	KTC2874B
Q317~318	HVTKTC3114A	T.R , BIAS	KTC3114A
Q301~306,311,312	HVTKTC3200GRT	T.R	KTC3200GR
Q315,316	HVTKTC3423Y	T.R , PRE DRIVE	KTC3423Y
Q321,322	BVT2SB1570P	T.R , POWER(DARINGTON)	
Q319,320	BVT2SD2401P	T.R , POWER(DARINGTON)	
Q331	KVTKSA1175YT	T.R	KSA1175Y
Q323~324,333,334,601	KVTKSC2785YT	T.R	KSC2785Y
IC11,14,16,21,41-43	HVINJM2068MDTE1	I.C , OP AMP	NJM2068MD-TE1
IC13	HVITC9163AF	I.C , FUNCTION	TC9163AF
IC12	HVITC9164AF	I.C , FUNCTION	TC9164AF
IC15	HVITC9459F	I.C , VOLUME	TC9459F
IC61	HVIL7805CP	I.C, REGULATOR	L7805CP
IC64	HVIL7815CP	I.C REGULATOR	7815CP
IC65	HVIL7915CP	I.C REGULATOR	7915CP
<i>Miscellaneous</i>			
L101,102	HLQ02C470KT	COIL , AXAIL	47UH
L301,302	CLEY0R5KAK	COIL , SPEAKER	0.5UH K
BN64	CWB1C906200BM	WIRE ASS'Y	
BN63	CWB3FE03280UP	WIRE ASS'Y	
BN62	CWB4FA32120PU	WIRE ASS'Y	
BN26	CWC1C4A13B170B	CARD , CABLE	
JW31	CWE7202050AA	WIRE ASS'Y	
JW33	CWE7202060AA	WIRE ASS'Y	
JW32	CWE7202070AA	WIRE ASS'Y	
JW34,35	CWE7202090AA	WIRE ASS'Y	
CN26	CJP13GA115ZY	WAFER , CARD CABLE	
CN81	CJP20GA147ZW	20 DUAL WAFER	JWT
CN31~32	KJP02GA01ZM	WAFER	MOLEX 5267-02A
CN75	KJP02GA19ZM	WAFER	
CN61	KJP02KA060ZY	WAFER	7.92MM(YUNHO)
CN73,74	KJP03GA19ZM	WAFER	
CN82	KJP07GA19ZM	WAFER	MOLEX53014-0710
CN91	KJP09GA19ZM	WAFER	MOLEX53014-0910
CN71	KJP12GA19ZM	WAFER	
JK10	CJJ4N060Z	JACK , BOARD 2P (GOLD)	
JK11,12	CJJ4P014W	JACK , IN/OUT	

Ref. Designator	Part Number	Description	
JK13	CJJ4R019W	TERMINAL , IN/OUT	
JK14	CJJ4R021W	JACK , IN/OUT	
JK15	CJJ5Q006Z	TERMINAL , SPEAKER	
T602	CLT5J033ZU	TRANS , SUB	SR-68
RY61	HSL1A008ZE	RELAY	SDT-S-112DMR
RY31,32	HSL4A004ZU	RELAY	OSA-SS-212DM3
F601,603~604	KBA2C8000TLEY	LITTEL FUSE	T 8A L 250V
F602	KBA2D2500TLET	FUSE	T 2.5A L 250V
OL61	KJJ7A015Z	OUTLET , AC(UL/2P/SEP)	A204D0041P
TH31	KRTP42T7D330B	THERM SENSOR, POSISTOR	P42T7D330BW20
T601	CLT5V036ZU	TRANS , POWER	

TUNER

HK3480 Tuner is only available as a complete PCB Module - part# CNVKSTM9014MS07

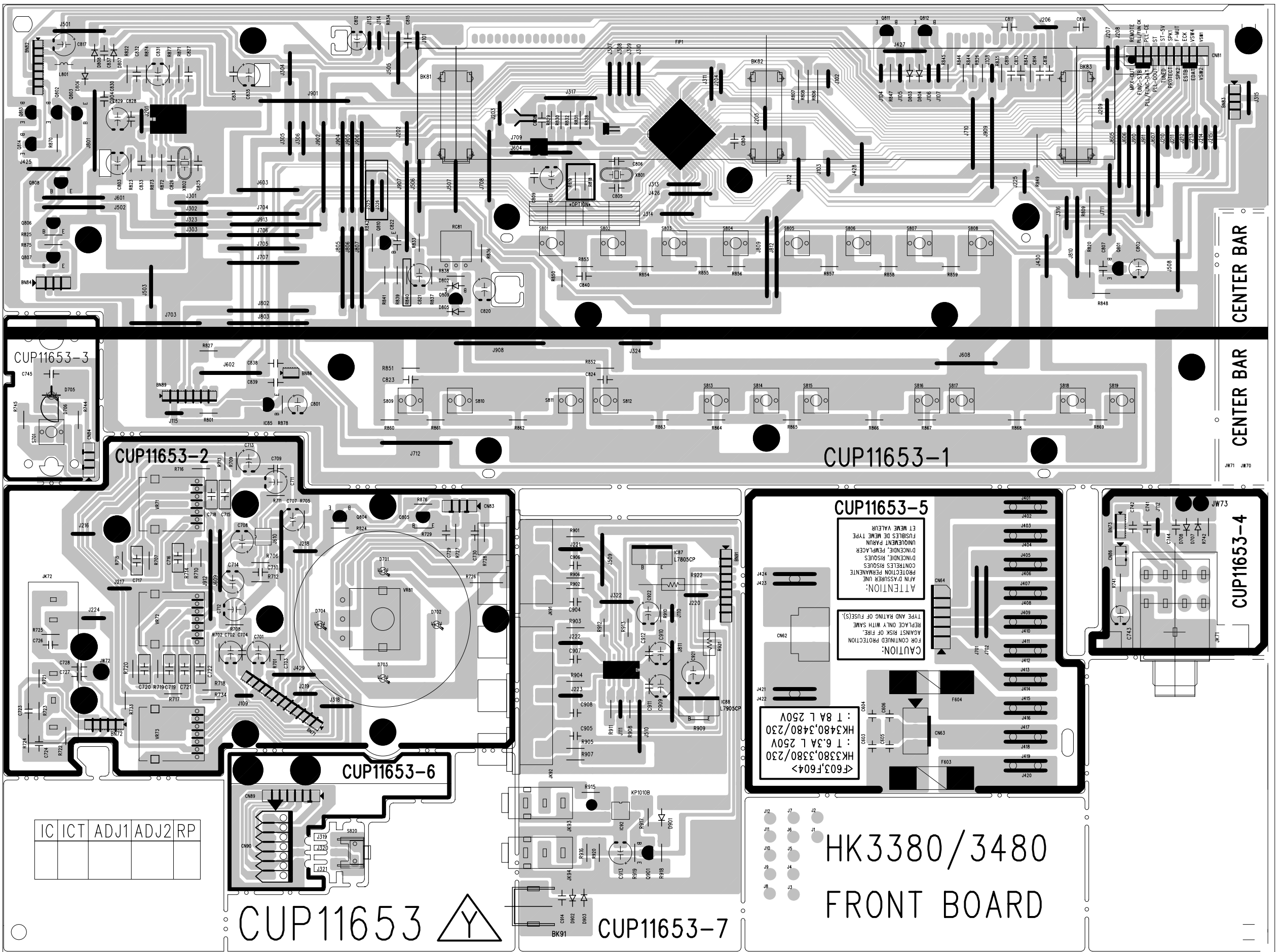

HK3380/3480
MAIN BOARD

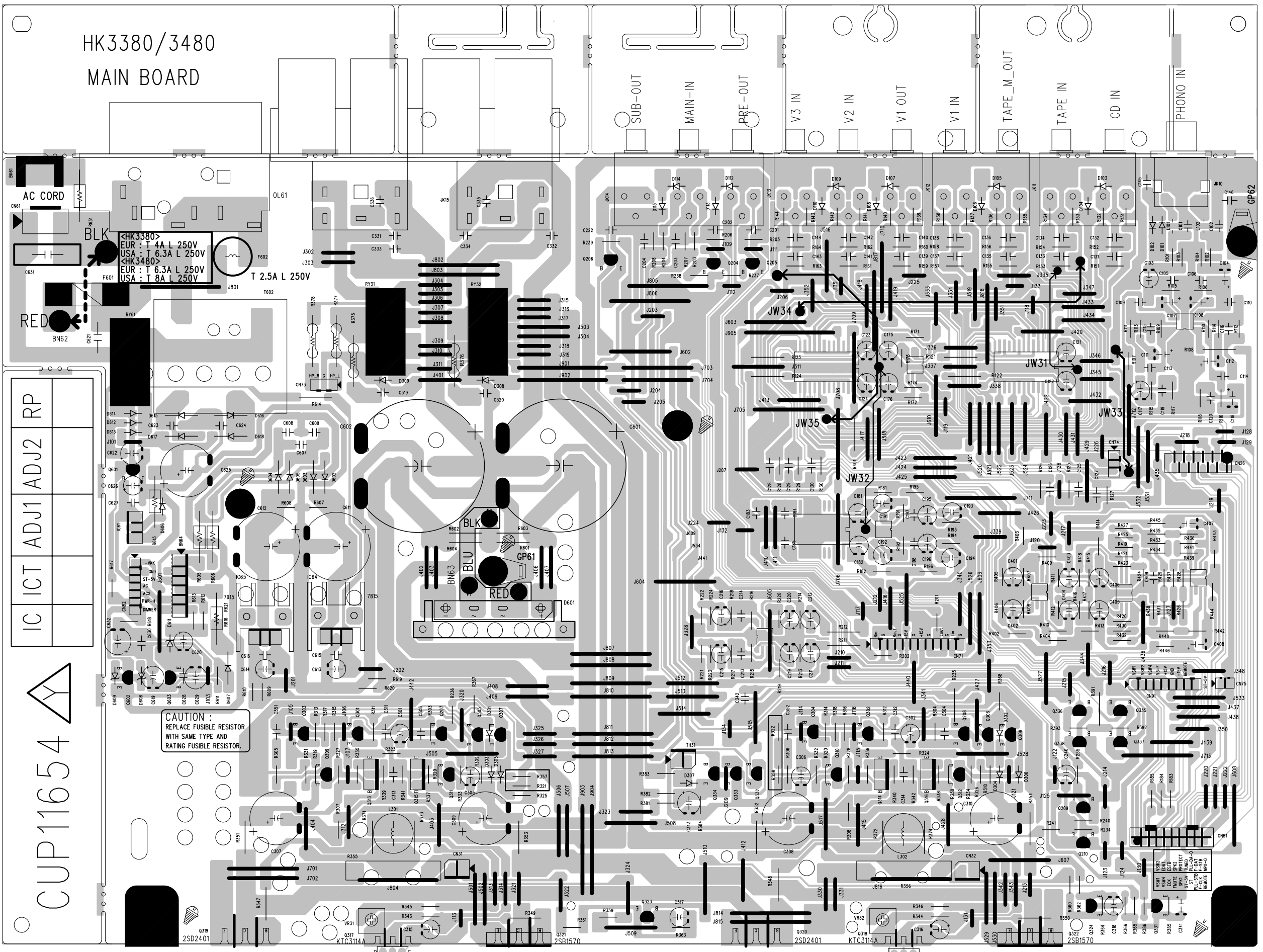

IC	ICT	ADJ1	ADJ2	RP

CUP11654

CAUTION :
REPLACE FUSIBLE RESISTOR
WITH SAME TYPE AND
RATING FUSIBLE RESISTOR.

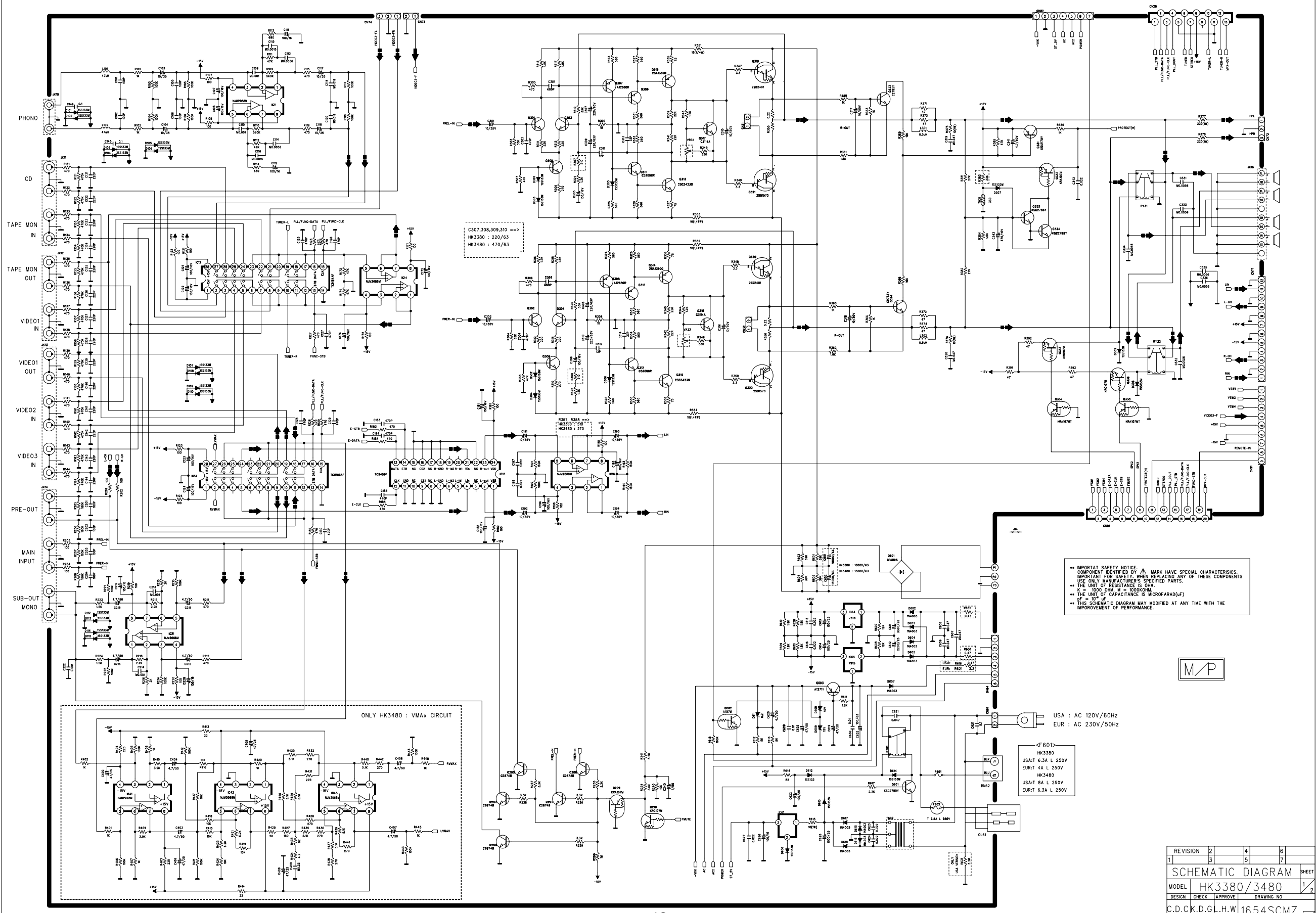

C307,308,309,310 =>
 HK3380 : 220/63
 HK3480 : 470/63

R257, R358 =>
 HK3380 : 500/270
 HK3480 : 270

•• IMPORTANT SAFETY NOTICE:
 COMPONENT IDENTIFIED BY Δ MARK HAVE SPECIAL CHARACTERISTICS.
 IMPORTANT FOR SAFETY: WHEN REPLACING ANY OF THESE COMPONENTS,
 USE ONLY MANUFACTURER'S SPECIFIED PARTS.
 •• THE UNIT OF RESISTANCE IS OHM.
 •• 1000 OHM = 1K OHM.
 •• 1000 OHM = 1000 OHM.
 •• PF = 10⁻¹² SECOND.
 •• THIS SCHEMATIC DIAGRAM MAY MODIFIED AT ANY TIME WITH THE
 IMPROVEMENT OF PERFORMANCE.



USA : AC 120V/60Hz
 EUR : AC 230V/50Hz

601
 HK3380
 USA:T 6.3A L 250V
 EUR:T 4A L 250V
 HK3480
 USA:T 8A L 250V
 EUR:T 6.3A L 250V

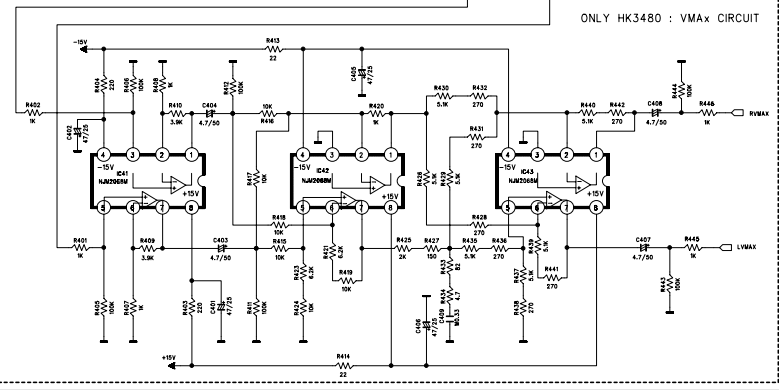

REVISION	2	4	6
1	3	5	7
SCHEMATIC DIAGRAM SHEET			
MODEL	CHK	3480	1/2
DESIGN	CHECK	APPROVE	DRAWING NO
C.D.C.K.D.G.L.H.W			1654-SCMZ
03.07.20			

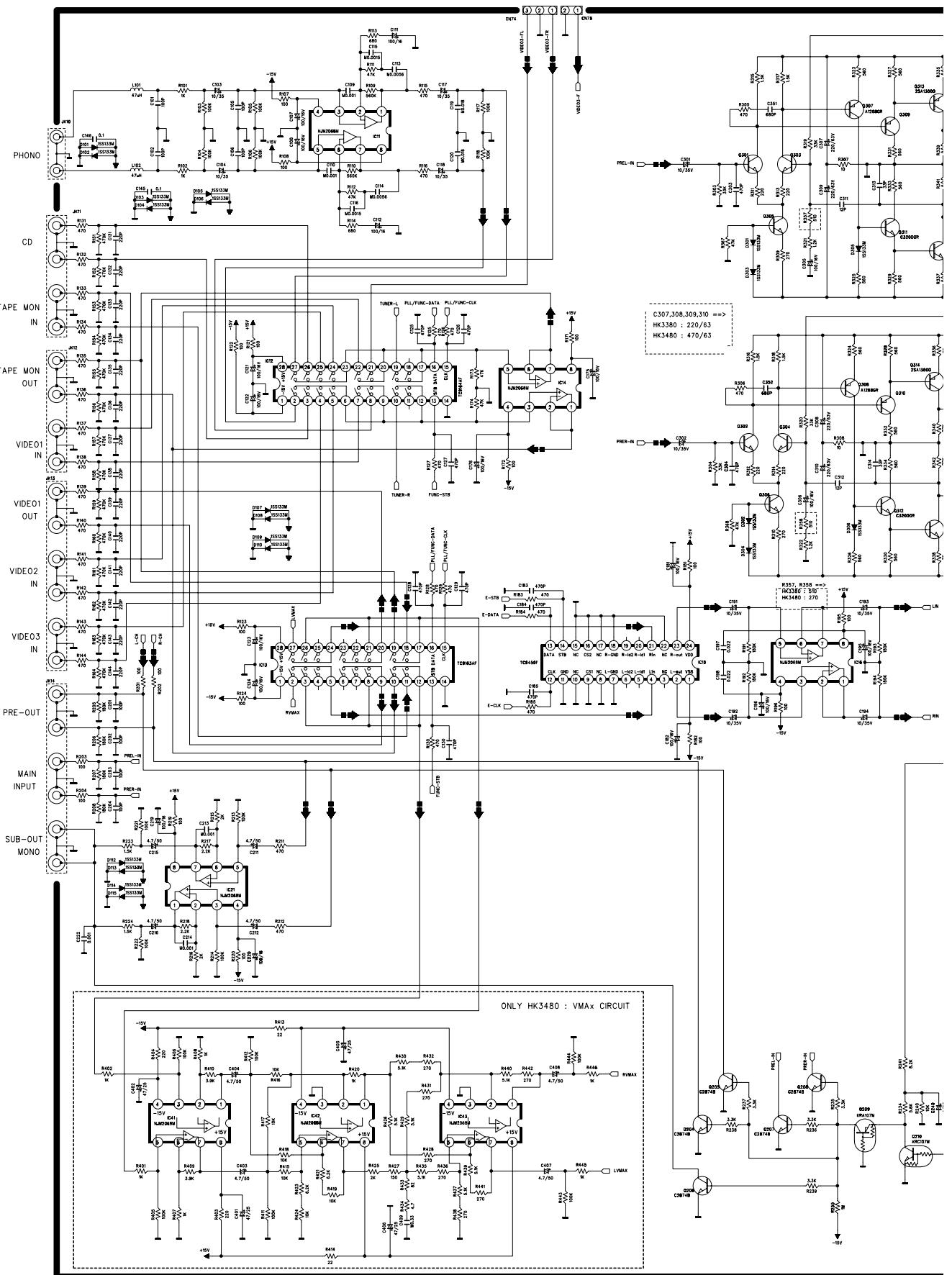

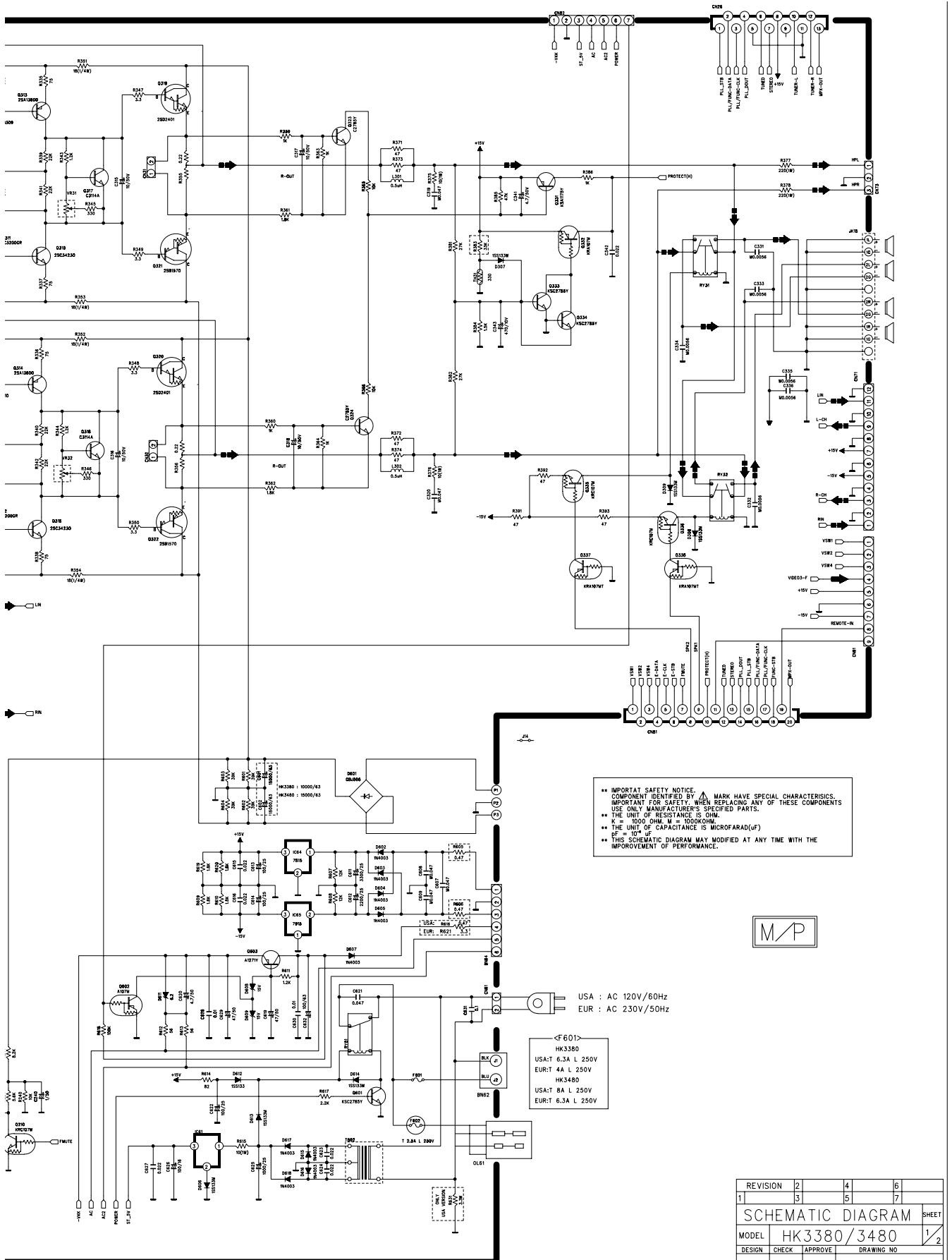

IMPORTANT SAFETY NOTICE:
 COMPONENT IDENTIFIED BY MARK HAVE SPECIAL CHARACTERISTICS.
 IMPORTANT FOR SAFETY: WHEN REPLACING ANY OF THESE COMPONENTS
 USE ONLY MANUFACTURER'S SPECIFIED PARTS.
 • THE UNIT OF RESISTANCE IS OHM.
 K = 1000 OHM, M = 100000 OHM.
 • THE UNIT OF CAPACITANCE IS MICROFARAD (uF)
 uF = 10⁻⁶ FARAD
 • THIS SCHEMATIC DIAGRAM MAY MODIFIED AT ANY TIME WITH THE
 IMPROVEMENT OF PERFORMANCE.



USA : AC 120V/60Hz
 EUR : AC 230V/50Hz

<F601>
 HK3380
 USA:T 6.3A L 250V
 EUR:T 4A L 250V
 HK3480
 USA:T 8A L 250V
 EUR:T 6.3A L 250V

REVISION	2	4	6
	3	5	7
SCHEMATIC DIAGRAM			
MODEL	HK3380/3480		
DESIGN	CHECK	APPROVE	DRAWING_NO
C.D.C.K.D.G.L.H.W			1654SCMZ
03.07.20			

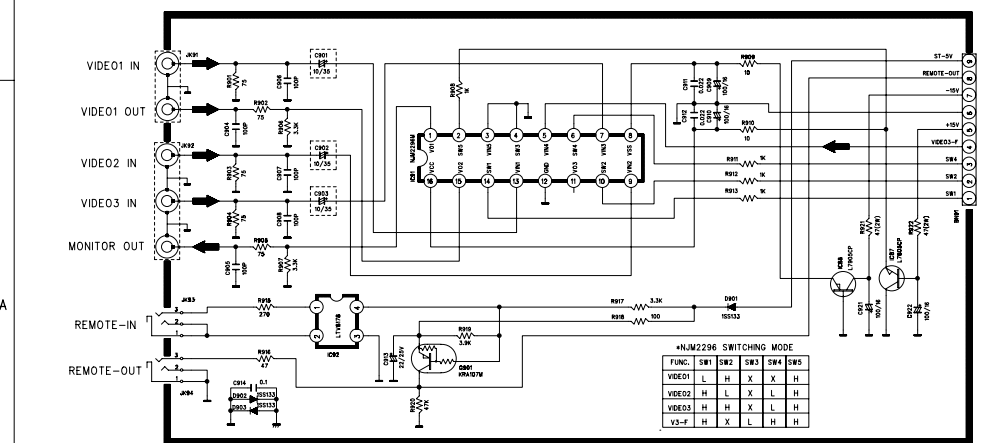
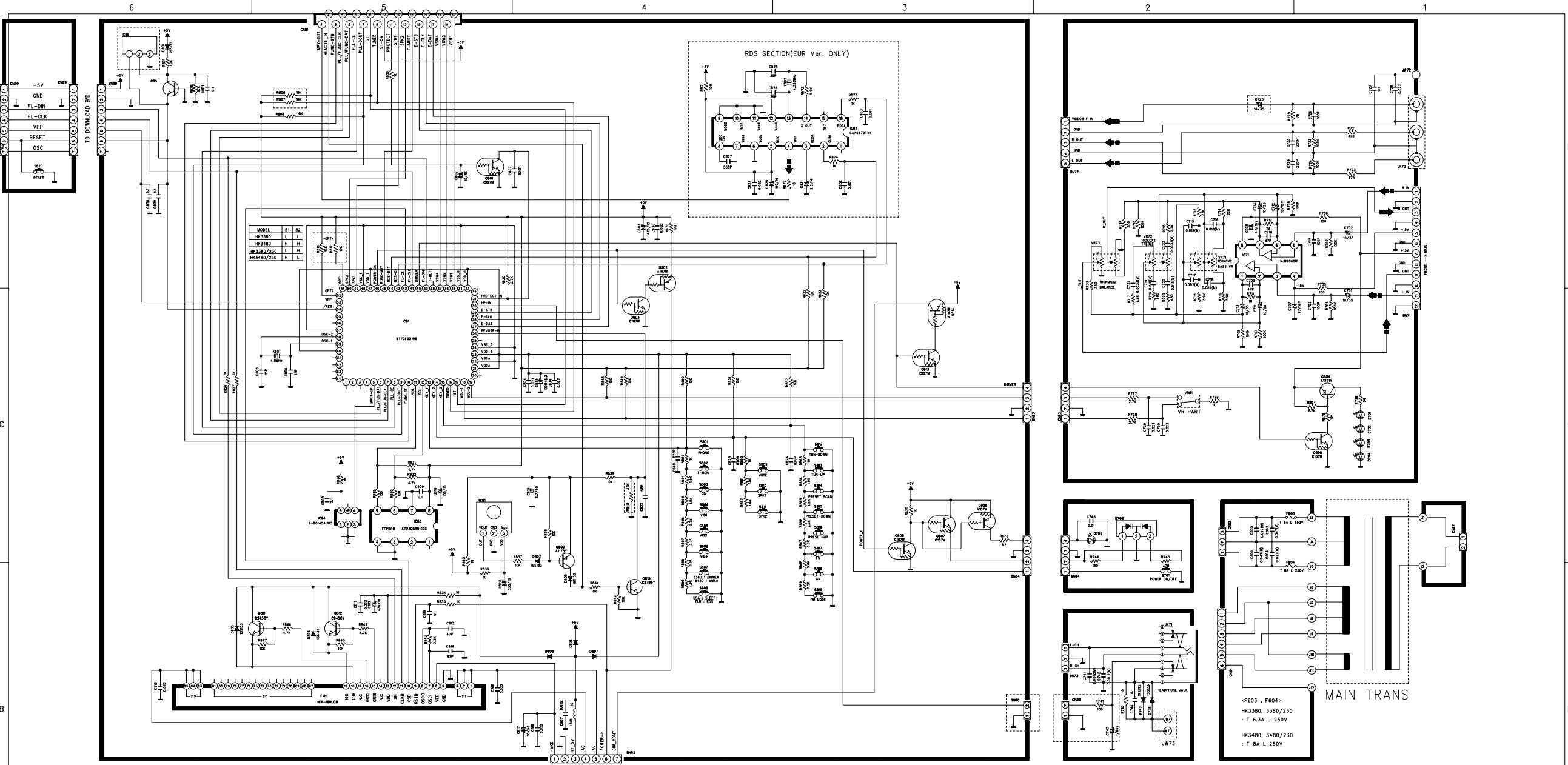

4001
4002
4003
4004
4005
4006
4007
4008
4009
4010
4011
4012
4013
4014
4015
4016
4017
4018
4019
4020
4021
4022
4023
4024
4025
4026
4027
4028
4029
4030
4031
4032
4033
4034
4035
4036
4037
4038
4039
4040
4041
4042
4043
4044
4045
4046
4047
4048
4049
4050
4051
4052
4053
4054
4055
4056
4057
4058
4059
4060
4061
4062
4063
4064
4065
4066
4067
4068
4069
4070
4071
4072
4073
4074
4075
4076
4077
4078
4079
4080
4081
4082
4083
4084
4085
4086
4087
4088
4089
4090
4091
4092
4093
4094
4095
4096
4097
4098
4099
4100

- IMPORTANT SAFETY NOTICE. COMPONENTS IDENTIFIED BY MARK SPECIAL CHARACTERISTICS. IMPORTANT FOR SAFETY. WHEN REPLACING ANY OF THESE COMPONENTS USE ONLY MANUFACTURER'S SPECIFIED PARTS.
- THE UNIT OF RESISTANCE IS OHM.
K=1000 OHM, M=1000 KOHM
- THE UNIT OF CAPACITANCE IS MICROFARAD. (uF)
pF=10 uF
- THIS SCHEMATIC DIAGRAM MAY MODIFIED AT ANY TIME WITH THE IMPROVEMENT OF PERFORMANCE.

M/P

HK3480

harman/kardon

REVISION	2	4	6	
1	3	5	7	
SCHEMATIC DIAGRAM				SHEET
MODEL	HK3380/3480			1/2
DESIGN	CHECK	APPROVE	DRAWING NO	
C.D.C	K.D.G	L.H.W	1653SCMZ	
03.07.18			(FRONT)	

SECTION(EUR Ver. ONLY)

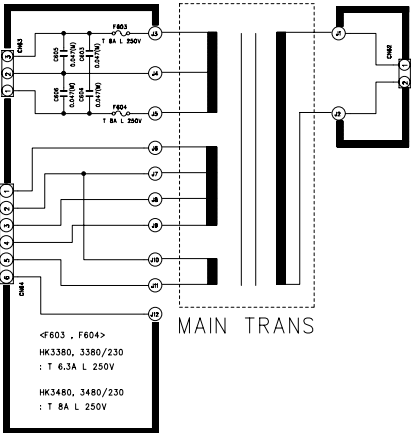
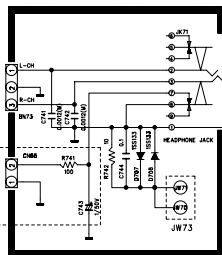
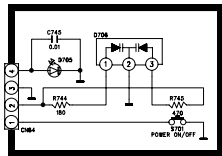
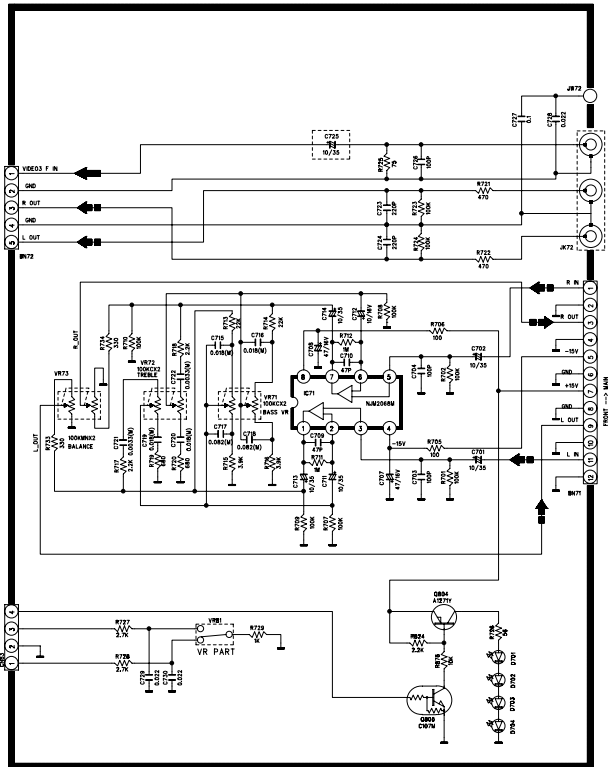
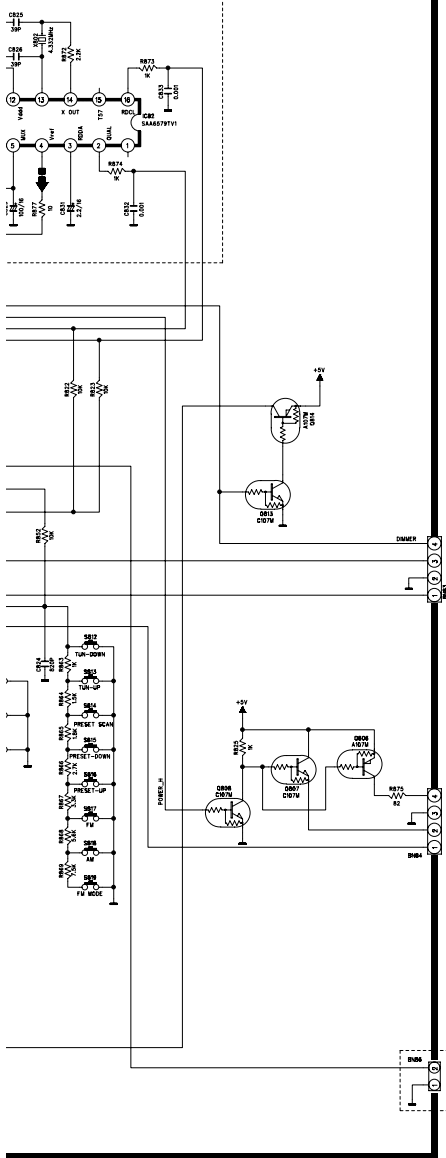

*IMPORTANT SAFETY NOTICE.
 COMPONENTS IDENTIFIED BY MARK SPECIAL CHARACTERISTICS.
 *IMPORTANT FOR SAFETY. WHEN REPLACING ANY OF THESE COMPONENTS
 ONLY MANUFACTURER'S SPECIFIED PARTS.
 UNIT OF RESISTANCE IS OHM.
 100 OHM, M=1000 KOHM
 UNIT OF CAPACITANCE IS MICROFARAD. (uF)
 10 uF
 SCHEMATIC DIAGRAM MAY MODIFIED AT ANY TIME WITH THE
 IMPROVEMENT OF PERFORMANCE.



HK3480

harman/kardon

REVISION	2	4	6
1	3	5	7
SCHEMATIC DIAGRAM			SHEET
MODEL	HK3380/3480		1/2
DESIGN	CHECK	APPROVE	DRAWING NO
C.D.C	K.D.G	L.H.W	1653SCMZ
03.07.18			(FRONT)

HK3380/HK3480 WIRING DIAGRAM

120V 60Hz

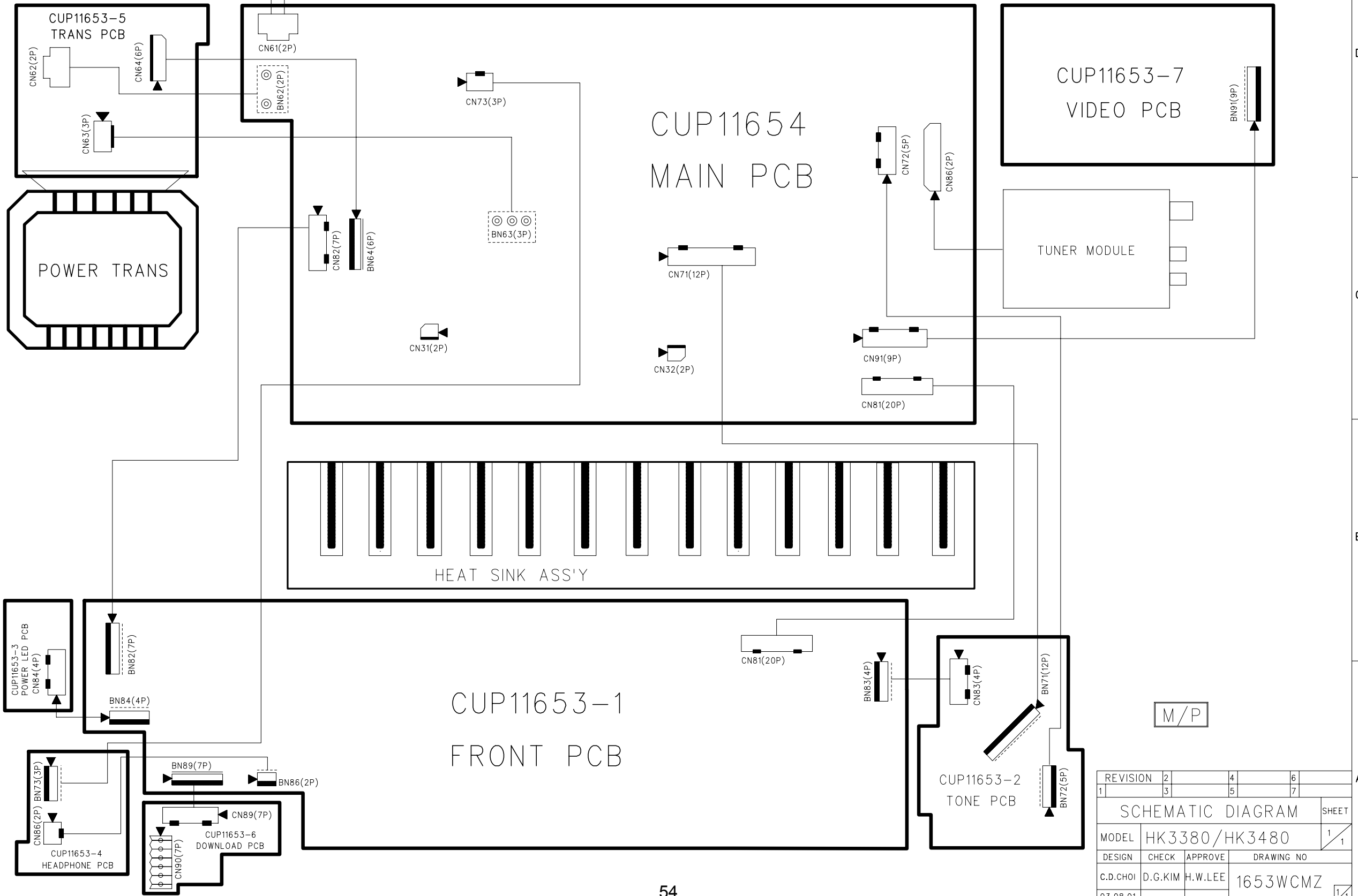

M/P

REVISION	2	4	6	
1	3	5	7	
SCHEMATIC DIAGRAM				SHEET
MODEL	HK3380/HK3480			1/1
DESIGN	CHECK	APPROVE	DRAWING NO	
C.D.CHOI	D.G.KIM	H.W.LEE	1653WCMZ	
03.08.01				1/1

1. Instruction manual ass'y – Accessories

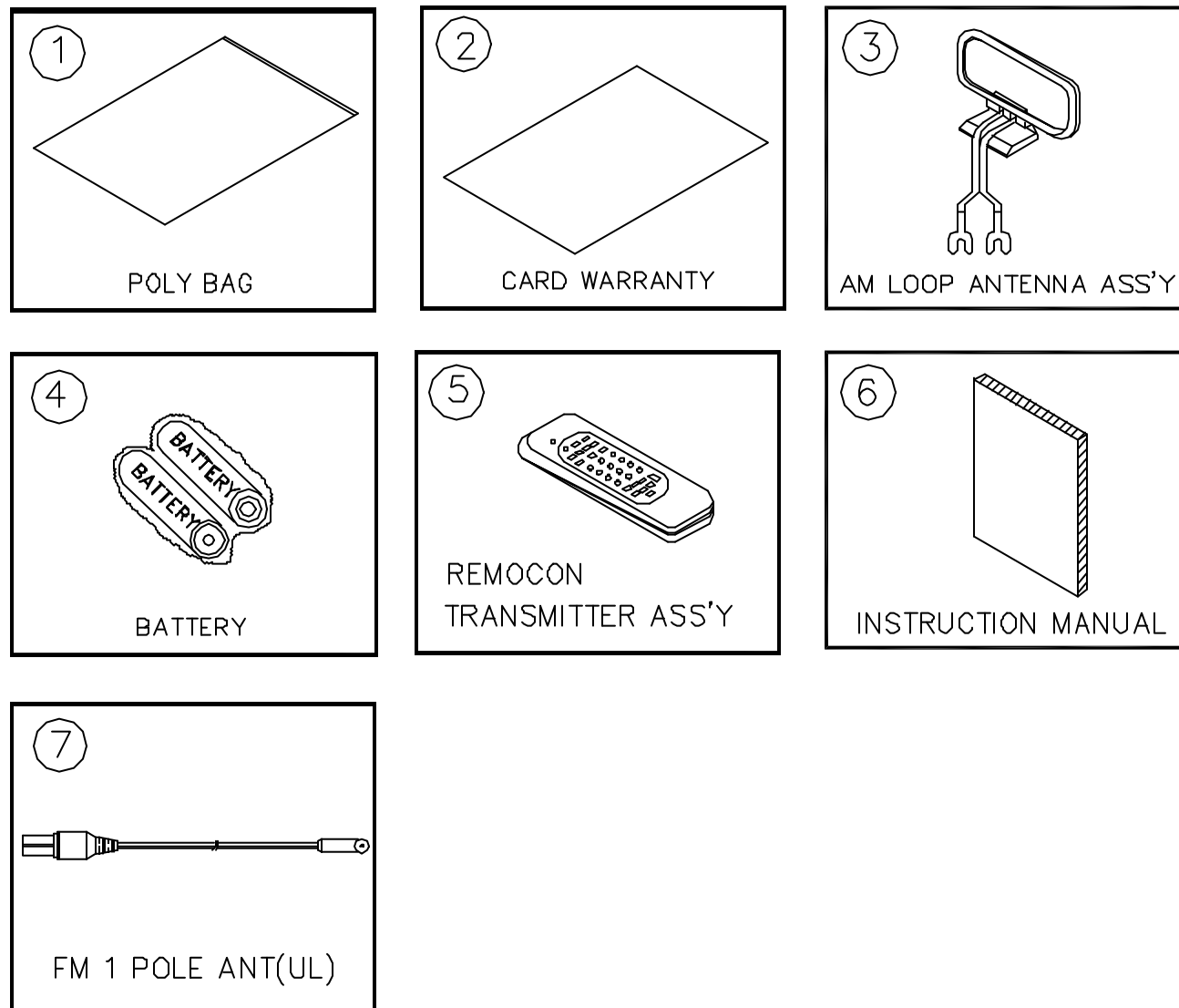

NO	DESCRIPTION	PARTS NO.	Q,ty
1	POLY BAG		1
2	CARD WARRANTY	CQE1A172X	1
3	AM LOOP ANTENNA ASS'Y	CSA3A012Z	1
4	BATTERY		2
5	REMOCON TRANSMITTER ASS'Y	HG5H02	1
6	INSTRUCTION MANUAL	CQX1A889Z	1
7	FM 1 POLE ANT(UL)	CSA1A019Z	1

2. Package Drawing

HK3480

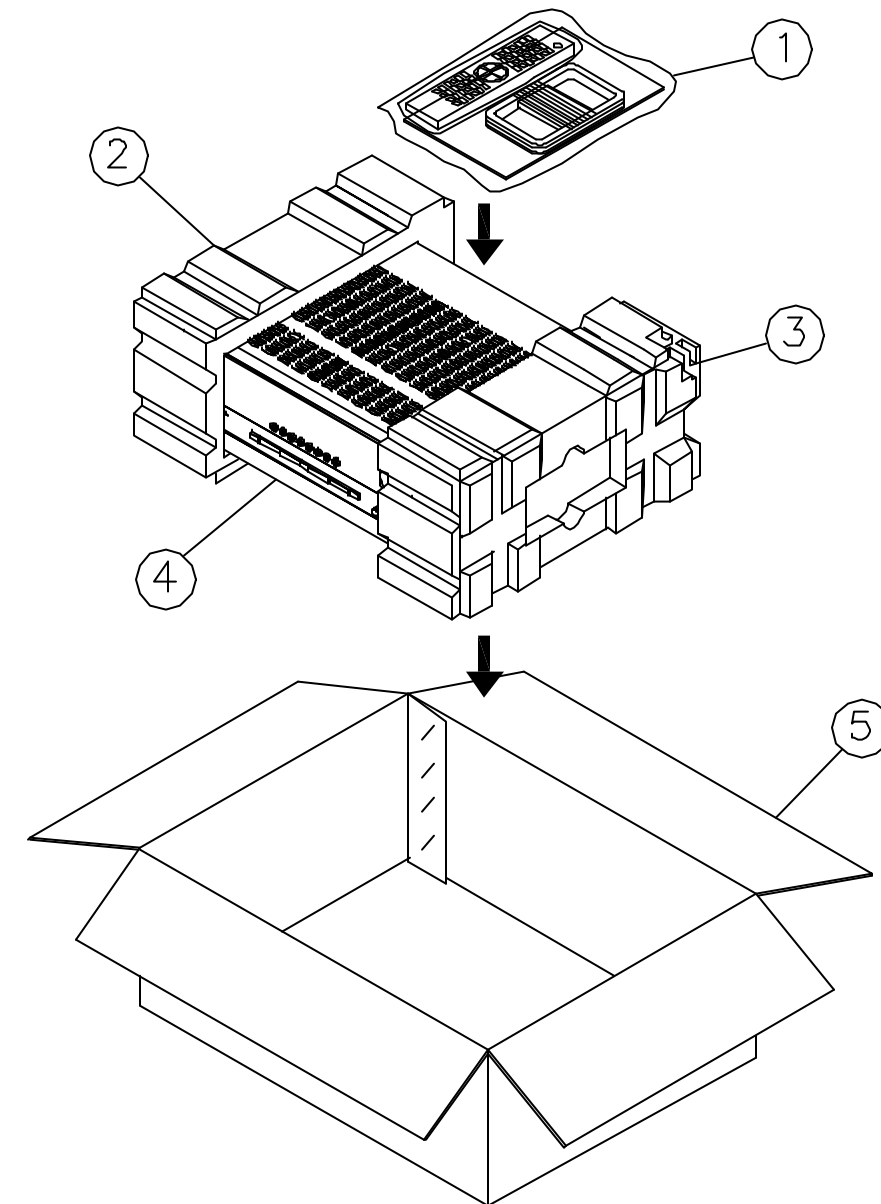

NO	DESCRIPTION	PARTS NO.	Q,ty
1	INSTRUCTION MANUAL ASS'Y		1
2	SNOW PAD(L)	CPS4A564	1
3	SNOW PAD(R)	CPS4A565	1
4	SET		1
5	BDX	CPG1A743X	1